

Joint Network Secretariat
Normal Procedure Task Force
Broken wheels

Brussels, 28. November 2019

Final output

Table of Content

1. Introduction and principles
2. Long term mitigation measures
3. Proposal for amendments in standards and regulation
4. Complementary investigation and activities
5. Background information
6. Financial impact JNS Task Force “Broken wheels”
7. Summary

1. Introduction and principles

Follow up to short term mitigation measures

In 2016/2017 broken and cracked wheels BA 314 / ZDB29 (with a slope under the wheel flange) and BA004 in some applications in the European rail freight business occurred. To mitigate the risk on 28th July 2017 short term measures in operation, wagon maintenance and off vehicle wheelset maintenance were disseminated.

In the second phase the Joint Network Secretariat Task Force “Broken wheels”– normal procedure performed in-depth analysis.

The present document replace and updates the “Short term mitigation measures” and defines long-term measures and proposal for updating the standards, regulations and contractual arrangements.

crack in the web

BA314 / ZDB29 (with a slope under the wheel flange)

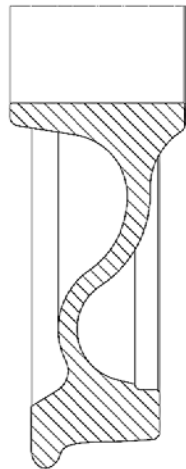

crack in the rim

BA 004

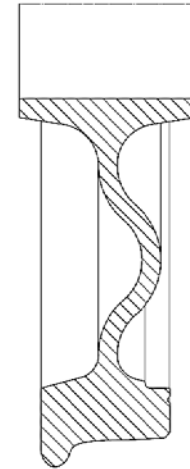

Background information of the JSG analysis are summarized in “JNS-NP-TF-Broken wheels-Final backup.pdf” and shared insight the JNS “Broken wheels”.

1. Introduction and principles

Definition of affected ECM and affected application

Affected ECM (BA 0004 and BA 314/ZDB 29)

ECM which uses the defined wheel types and may be faced with similar defects (broken wheels and cracks in rim and web) which have to be checked by every ECM under its own responsibility based on a documented risk analysis.

Affected application for BA 004 (“crack in the rim”)

The analyse has demonstrated, that in some applications the probability for the development of thermally initiated defects is higher.

The following conditions need to be considered in the risk analysis:

Waggon type / configuration

- Type of traffic (combined traffic or not)
- brake input (high or not)
- Brake blocks (composite or not)
- wheel diameter (below 860 mm or not)

Operational conditions – predominant use in

- Alp crossing or not
- Northern countries or not

Special waggon design

- articulated waggon – middle bogie or not

By combination of these conditions and with an increase of the number of conditions the probability of defects increase. This has to be checked by every ECM under its own responsibility integrated in the documented risk analysis.

1. Introduction and principles

Final result– Cluster “Crack in the web” BA 314/ZDB 29 (with slope under the rim)

Result	<ul style="list-style-type: none">• Apply the final output of the JNS Normal procedure TF “Broken wheels” for the BA 314/ZDB 29 with slope under the rim• BA 314/ ZDB 29 with slope under the rim is in the context of the JNS results not longer considered as a thermostable wheel.• For the improved wheel design (rim without slope) no measures necessary.
Motivation/ reason	<ul style="list-style-type: none">• The calculation of the wheel without the slope under the rim demonstrates a significant reduction of the stresses in the critical part of the web (see next slide)
Proposed place/ way for implementation	<ul style="list-style-type: none">• Application of the JNS results
To apply by	<ul style="list-style-type: none">• all

1. Introduction and principles

Final result– Cluster “Crack in the web” BA 314/ZDB 29 (with slope under the rim)

Additional information about BA 314/ ZDB 29

The wheel types BA 314 / ZDB 29 were produced in two versions.

The new version (build after 2006) is **not** affected by relevant failures and can therefore be excluded from the special measures for wheel types BA 314/ ZDB 29.

Definition:

Wheelset type BA 314 / ZDB 29 with a slope under the wheel flange (probably produced until 2005/2006)

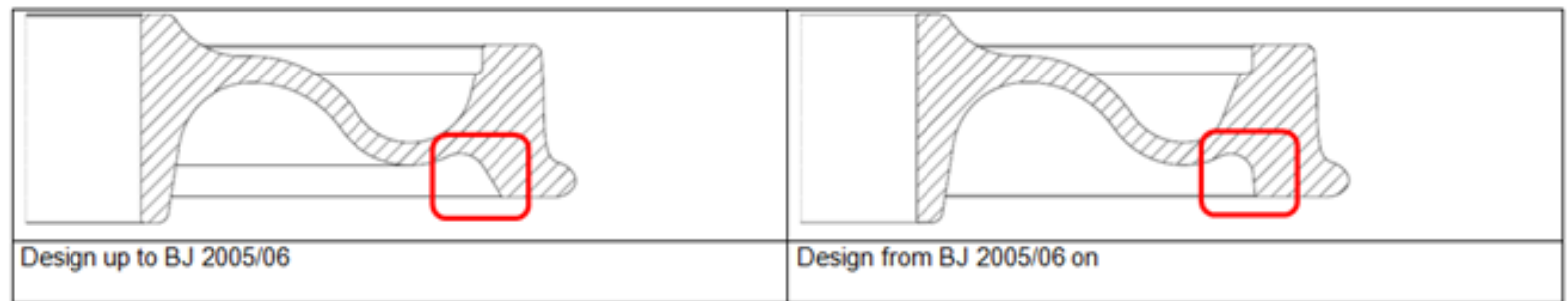

1. Introduction and principles

Final result– Cluster “Crack in the web” BA 314/ZDB 29 (with slope under the rim)

BA 314/ZDB 29 – comparison of the design

Wheel with slope - old design

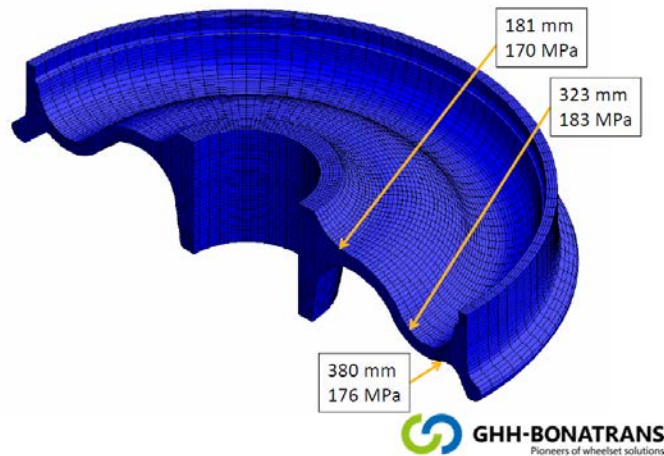

- Position of critical point is in web on radius 323 mm on outer side.
- maximal stress amplitude in critical point of wheel web is 183 MPa.
- Stress amplitude in the area of crack (in inner side of web on radius 380 mm) is 176 MPa.

Wheel without slope – new design

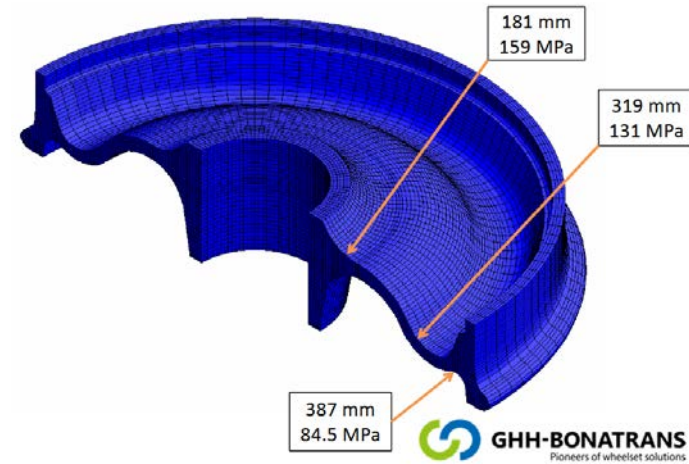

- Position of critical point is in transition between hub-web on radius 181 mm.
- maximal stress amplitude in critical point of wheel web is 159 MPa.
- Stress amplitude in the area of crack (in inner side of web on radius 387 mm) is 84.5 MPa.

Conclusion: Change of design (without slope) reduces stresses in the web and in particular in the area of the crack initiation.

1. Introduction and principles

Final result – Cluster “Crack in the rim” BA 004

Result	<ul style="list-style-type: none">• Apply the final output of the JNS Normal procedure TF “Broken wheels” for the BA 004• BA 004 is in the context of the JNS results not longer considered as a thermostable wheel
Motivation/ reason	<ul style="list-style-type: none">• reduce thermal overload of the wheels
Proposed place/ way for implementation	<ul style="list-style-type: none">• Application of the JNS results
To apply	<ul style="list-style-type: none">• all

2. Long term mitigation measures

2.1. Operation and wagon maintenance – BA 004 and BA 314/ZDB 29

Measure	Visual inspection of the wheels before departure	Inspection of the wheels during change of brake blocks (in and outside of workshop)	
To apply	All RU	All affected ECM in case of order repairs	In case of GCU repairs.
Scope	<ul style="list-style-type: none"> Tread braked wagons all wheel types (even wheels with white stripe) limited to visible parts of the wheel 	<ul style="list-style-type: none"> Tread braked wagons wheel design BA 314 / ZDB29 (with a slope under the wheel flange) and BA004 limited to visible parts of the wheel 	<ul style="list-style-type: none"> Tread braked wagons Wheels without white stripes limited to visible parts of the wheel
Criteria	Visual inspection: <ul style="list-style-type: none"> single cracks on the wheel tread* Cracks in rim and web (Annex 9 GCU) any indication of thermal overload of the wheel (Annex 9 GCU)** Check release of the handbrake 	Visual inspection: <ul style="list-style-type: none"> single cracks on the wheel tread* Cracks in rim and web any indication of thermal overload of the wheel** Sound checks of the wheel *** Optional: White stripe suppression (depending on environmental conditions) 	Visual inspection: <ul style="list-style-type: none"> single cracks on the wheel tread Cracks in rim and web any indication of thermal overload of the wheel
Measures on findings:	<ul style="list-style-type: none"> dispatch wagon to workshop Off vehicle wheelset maintenance (ECM) 	<ul style="list-style-type: none"> dispatch wagon to workshop Off vehicle wheelset maintenance (ECM) 	<ul style="list-style-type: none"> dispatch wagon to workshop Off vehicle wheelset maintenance (ECM)
Status 11/2019	<ul style="list-style-type: none"> Already implemented in GCU for all brake block types - only reminder 	<ul style="list-style-type: none"> individual 	<ul style="list-style-type: none"> See proposal amendment GCU

* single cracks on the wheel tread (“isolated transverse cracking” cf. EN 15313 §C.2.6 and 6.2.3.4) – Criteria: see slide 39

** any indication of thermal overload of the wheel (burnt paint, excessive wheel deformation, cf. EN 15313 §C.3.2.2 and 6.2.4.3) – Criteria: see slides 40, 41

*** sound test: see slides 42, 43

Amendments to the short term mitigation measures from 2017 highlighted in yellow

2. Long term mitigation measures

2.2 Operation and wagon maintenance – BA 004 and BA 314/ZDB 29

Measure	Information to the Workshops	Visual inspection of the wheels in workshops (complementary to EVIC)	
To apply	All affected ECM	In case of GCU repairs: All ECM and RU	In case of ordered repairs: All affected ECM
Scope	<ul style="list-style-type: none"> Information to the Workshops on ECM's instructions wheel design BA 314 / ZDB29 (with a slope under the wheel flange) and BA004 	<ul style="list-style-type: none"> wheel BA 314 / ZDB29 (with a slope under the wheel flange) and BA004 In case the concerned wheel types cannot be clearly identified - Systematic for all wheel types If wheel design clearly identified is not BA 004, BA 314/ZDB 29 (with a slope under the wheel flange): no specific measures are needed 	<ul style="list-style-type: none"> wheel designs BA 314 / ZDB29 (with a slope under the wheel flange) and BA004
Criteria	<ul style="list-style-type: none"> Order visual inspection during change of brake blocks White stripe suppression Implement measures in "off vehicle Wheelset maintenance" Individual relevant measures (e.g. maintenance plan, equipment, mileage) 	Visual inspection: <ul style="list-style-type: none"> single cracks on the wheel tread* Cracks in rim and web any indication of thermal overload of the wheel** 	Visual inspection: <ul style="list-style-type: none"> single cracks on the wheel tread Cracks in rim and web any indication of thermal overload of the wheel White stripe suppression
Measures on findings:	<ul style="list-style-type: none"> E.g. Maintenance plan review, braking equipment adaptation 	<ul style="list-style-type: none"> Off vehicle wheelset maintenance (ECM) 	<ul style="list-style-type: none"> Off vehicle wheelset maintenance (ECM)
Status 11/2019	<ul style="list-style-type: none"> individual 	<ul style="list-style-type: none"> individual 	<ul style="list-style-type: none"> individual

* single cracks on the wheel tread ("isolated transverse cracking" cf. EN 15313 §C.2.6 and 6.2.3.4) – Criteria: see slide 39

** any indication of thermal overload of the wheel (burnt paint, excessive wheel deformation, cf. EN 15313 §C.3.2.2 and 6.2.4.3) – Criteria: see slides 40, 41

Amendments to the short term mitigation measures from 2017 highlighted in yellow

2. Long term mitigation measures

2.3 Off vehicle wheelset maintenance – BA 004 (“crack in the rim”)

Measure	Elimination of the identification for thermostable wheels	Intensified measures after findings in operation and wagon maintenance	Stronger criteria for residual stress measurements	Wheel diameter recommendation
To apply	All affected ECM	All affected ECM	All affected ECM	All affected ECM
Scope	<ul style="list-style-type: none"> BA 004 	<ul style="list-style-type: none"> BA004 	<ul style="list-style-type: none"> BA004 	<ul style="list-style-type: none"> BA 004 in affected application (see slide 4)
Measure (see also boundary conditions)	<ul style="list-style-type: none"> remove white stripe marking on bearing box cover 	<ul style="list-style-type: none"> Measures after thermal overload: <ul style="list-style-type: none"> Residual stress measurement* Measurement back to back distance between the wheels Reprofiling NDT of the tread* <p>*alternative: systematic reprofiling of large depth in diameter and visual inspection of the tread according to service experience</p>	<ul style="list-style-type: none"> First check and after signs of thermal overload Generally reduced limit 300 MPa instead of 400 MPa 	<p>Wheel Diameter recommendation:</p> <ul style="list-style-type: none"> In service limit ≥ 860 mm <p>To fulfill these recommendation a suitable diameter for the last reprofiling has to be chosen.</p>
Status 11/2019	<ul style="list-style-type: none"> individual 	<ul style="list-style-type: none"> individual 	<ul style="list-style-type: none"> individual 	<ul style="list-style-type: none"> individual

Amendments to the short term mitigation measures from 2017 highlighted in yellow

2. Long term mitigation measures

2.4 Off vehicle wheelset maintenance – BA 314/ZDB 29 with slope under rim

Measure	Elimination of the identification for thermostable wheels	Intensified measures after findings in operation and wagon maintenance	Stronger criteria for residual stress measurements	NDT of the web
To apply	All affected ECM	All affected ECM	All affected ECM	All affected ECM
Scope	<ul style="list-style-type: none"> wheel designs BA 314 / ZDB29 (with a slope under the wheel flange) 	<ul style="list-style-type: none"> wheel designs BA 314 / ZDB29 (with a slope under the wheel flange) 	<ul style="list-style-type: none"> wheel designs BA 314 / ZDB29 (with a slope under the wheel flange) 	<ul style="list-style-type: none"> wheel designs BA 314 / ZDB29 (with a slope under the wheel flange) - all application
Measure (see also boundary conditions)	<ul style="list-style-type: none"> remove white stripe marking on bearing box cover 	<ul style="list-style-type: none"> Measures after thermal overload: <ul style="list-style-type: none"> Residual stress measurement* Measurement back to back distance between the wheels Reprofiling NDT of the tread* *alternative: systematic reprofiling of large depth in diameter and visual inspection of the tread according to service experience 	<ul style="list-style-type: none"> First check and after signs of thermal overload Generally reduced limit 300 MPa instead of 400 MPa 	<ul style="list-style-type: none"> All steps in off vehicle wheelset maintenance: NDT of the web
Status 11/2019	<ul style="list-style-type: none"> individual 	<ul style="list-style-type: none"> individual 	<ul style="list-style-type: none"> individual 	<ul style="list-style-type: none"> individual

Amendments to the short term mitigation measures from 2017 highlighted in yellow

2. Long term mitigation measures

2.5 Data collection after incidents of tread braked wheels

Result	<ul style="list-style-type: none">• Harmonized way of inspection program after incidents of tread braked wheels “Information collection for broken or cracked wheels”
Motivation/ reason	<ul style="list-style-type: none">• Best practice for collection of information after wheel incidents to allow appropriate analysis based on “List of cases”• Collection of information of wheels:<ul style="list-style-type: none">• with incident = cracked across the rim or web• for all wheel types
Proposed place/ way for implementation	<ul style="list-style-type: none">• Distribution with final JNS document: “Template_for_analysis_cracked_wheels.xlsx”
To apply	<ul style="list-style-type: none">• All
Responsible for implementation in official references	<ul style="list-style-type: none">• -

3. Proposal for amendments in standards and regulation

3.1 General recommendation for the sector in respect of JNS

Result	<ul style="list-style-type: none">• strict use of the Joint Network Secretariat to tread general safety issues and to mitigate risks• Mandatory implementation of JNS results
Motivation/ reason	<ul style="list-style-type: none">• Harmonized and reactive European way to handle safety relevant issues• improve safety culture and avoid national measures
Proposed place/ way for implementation	<ul style="list-style-type: none">• Distribution by the sector organization• Publication on the ERA website• Implementation by the stakeholders and supervision by the NSAs as mandatory measure• Integration in the principles of the future CSM on Assessment of Safety level and Performance• Implementation in GCU (as generic article) for the principle
To apply	<ul style="list-style-type: none">• All
Responsible for implementation in official references	<ul style="list-style-type: none">• ERA/ NSAs/ Sector

3. Proposal for amendments in standards and regulation

3.2 Improvement of the design of tread braked wheels - calculation

Result	<ul style="list-style-type: none">• Harmonization of the thermomechanical calculation acc. EN 13 979-1 based on UIC B169, RP 17 and RP 1
Motivation/ reason	<ul style="list-style-type: none">• improved thermomechanical pre-dimensioning of tread braked wheels
Proposed place/ way for implementation	<ul style="list-style-type: none">• EN 13 979-1 - Monobloc wheels - Design assessment procedure — Part 1: Forged and rolled wheels• Optional: UIC 510-5 Technical approval of monobloc wheels, Application document for standard EN 13979-1
To apply	<ul style="list-style-type: none">• -
Responsible for implementation in official references	<ul style="list-style-type: none">• CEN WG 11

3. Proposal for amendments in standards and regulation

3.3 Improvement of the design of tread braked wheels- design recommendation

Result	Future wheel design: <ul style="list-style-type: none">• recommendation for application of a rim thickness in worn condition, value to define in the proposed Sector project• Recommendation for application of the suitable inner diameter on the inner and outer side of the rim to enable good conditions for residual stress measurement in maintenance and homologation
Motivation/ reason	<ul style="list-style-type: none">• low rim thickness have a potential influence to increase the probability for thermally initiated failure• Low rim thickness and/or not suitable inner rim diameter difference disable the residual stress measurement in worn conditions
Proposed place/ way for implementation	<ul style="list-style-type: none">• EN 13 979-1 - Monobloc wheels - Design assessment procedure — Part 1: Forged and rolled wheels
To apply	<ul style="list-style-type: none">• -
Responsible for implementation in official references	<ul style="list-style-type: none">• CEN WG 11

3. Proposal for amendments in standards and regulation

3.4 Distinction between different wheel geometries by own description

Result	<ul style="list-style-type: none">• Clear distinction between different wheel geometries by own description/ name (e.g. BA 314/ ZDB 29 old and new design)• Definition of a design type with a range of parameters under which the design is still homologated• Definition of process for assessing difference between two designs
Motivation/ reason	<ul style="list-style-type: none">• The analyses of the crack in the web case has demonstrated, that geometrical difference (e.g. web thickness, design of the rim) exist and the distinction was not possible.
Proposed place/ way for implementation	<ul style="list-style-type: none">• EN 13 979-1 - Monobloc wheels - Design assessment procedure — Part 1: Forged and rolled wheels
To apply	<ul style="list-style-type: none">• Wheel designer and manufacturer
Responsible for implementation in official references	<ul style="list-style-type: none">• CEN WG 11• ERA

3. Proposal for amendments in standards and regulation

3.5 Maintenance and operation: Measures after thermal overload of wheelsets

Result	Improved requirements for measures after thermal overload of wheels
Motivation/ reason	<ul style="list-style-type: none">• The crack in the rim was thermally initiated. An appropriate treatment of thermally overloaded wheelsets reduce the probability of failure.
Proposed place/ way for implementation	<ul style="list-style-type: none">• Mandatory implementation by the ECM• GCU – see proposal for amendment• EN 15 313 - In-service wheelset operation requirements - In-service and off vehicle wheelset maintenance
To apply	<ul style="list-style-type: none">• ECM
Responsible for implementation in official references	<ul style="list-style-type: none">• GCU• CEN WG 11

3. Proposal for amendments in standards and regulation

3.5 Maintenance and operation: Measures after thermal overload of wheelsets

On non-thermostable wheels (without white marks on the axle box cover) the following measures has to be performed on thermally overloaded wheels:

- Residual stress measurement*
- Measurement back to back distance between the wheels
- Reprofilng
- NDT of the tread*

* alternative: systematic reprofilng of large depth in diameter and visual inspection of the tread according to service experience

On thermostable wheels the measures has to be applied in the next scheduled off vehicle wheelset maintenance.



3. Proposal for amendments in standards and regulation

3.6 Detection of thermally overloaded wheels – use of thermo-sensitive paint

Result	<ul style="list-style-type: none">• Mandatory application of thermo-sensitive paint in tread braked freight application (new production and maintenance)
Motivation/ reason	<ul style="list-style-type: none">• The cracks in the rim were thermally initiated. An improved detection of thermally overloaded wheelsets reduce the probability of failure
Proposed place/ way for implementation	<ul style="list-style-type: none">• New wheels: EN 13 262 - Wheelsets and bogies — Wheels — Product requirements• Maintenance: EN 15 313 - In-service wheelset operation requirements - In-service and off vehicle wheelset maintenance
To apply	<ul style="list-style-type: none">• All
Responsible for implementation in official references	<ul style="list-style-type: none">• CEN WG 11

3. Proposal for amendments in standards and regulation

3.7 Application of the UIC guideline composite brake blocks

Result	<ul style="list-style-type: none">• Mandatory application of the UIC requirements from UIC leaflet 541-4, 543 for composite brake blocks
Motivation/ reason	<ul style="list-style-type: none">• UIC Guidelines/ leaflets are not mandatory for the whole sector. Therefore the requirements have to be integrated in EUROPEAN widespread regulations.• Right application of composite brake blocks (e.g. kink valve)• Reduction of thermal inhomogeneities in operation
Proposed place/ way for implementation	<ul style="list-style-type: none">• TSI WAG and/or OPE (supported by ERA with the help of UIC SET 7 and CEN WG 47)
To apply	<ul style="list-style-type: none">• All
Responsible for implementation in official references	<ul style="list-style-type: none">• ERA with support of UIC SET 7 and CEN WG 47

3. Proposal for amendments in standards and regulation

3.8 Proposal for GCU amendments – handling of thermally overloaded wheels (01/10)

Result	<ul style="list-style-type: none">• JNS “Broken wheels” propose mitigation measures to avoid cracked and broken wheels
Motivation/ reason	<ul style="list-style-type: none">• Direct proposal for the implementation of the JNS results in the GCU
Proposed place/ way for implementation	<ul style="list-style-type: none">• GCU
To apply	<ul style="list-style-type: none">• All
Responsible for implementation in official references	<ul style="list-style-type: none">• GCU JC

3. Proposal for amendments in standards and regulation

3.8 Proposal for GCU amendments – handling of thermally overloaded wheels (02/10)

Appendix 9, Annex 1: Technical Conditions for Wagon Transfers between Railway Undertakings

GCU 2019

Component	Code no.	Irregularities/Criteria/Notes	Action to be taken	Category
Solid wheel	1.2			
	1.2.1	Groove marking the minimum thickness is no longer fully visible in cross-section ²	Detach wagon	4
	1.2.2	Thermal overload due to braking <ul style="list-style-type: none">• recent paint burns of 50 mm or more at connection between rim and wheel plate• traces of rust on rim (plate not painted)• fusion of brake blocks• deterioration of wheel tread with build-up of metal (see also no. 1.3.4)	Proceed in accordance with Annex 8 point 3.	
	1.2.2.1	<ul style="list-style-type: none">• without gauge widening of the inner faces	K + R1 (isolate brake)	4
1.2.2.2	<ul style="list-style-type: none">• with gauge widening of the inner face	Detach wagon	5	

Proposal for amendment

1.2.2:

Thermal overload due to braking

- recently clearly burnt paint at connection between rim and wheel plate (paint cracked and peeled)
- traces of rust at connection between rim and wheel plate
- fusion of brake blocks
- deterioration of wheel tread with build-up of metal (see also no. 1.3.4)
- rim not uniformly bluish colored from overheating

Amendments to the GCU 2019 highlighted in yellow

3. Proposal for amendments in standards and regulation

3.8 Proposal for GCU amendments – handling of thermally overloaded wheels (03/10)

Appendix 9, Annex 1: Technical Conditions for Wagon Transfers between Railway Undertakings

GCU 2019

Component	Code no.	Irregularities/Criteria/Notes	Action to be taken	Category
Tyre or corresponding part of solid wheel <i>(continued)</i>	1.3.6	Cracks and notches		
	1.3.6.1	Crack at the interface between the wheel tread and the front edge	Detach wagon	5
	1.3.6.2	Sharp-angled notches on the front face (rim or inner tyre rim) caused by tools, track brakes or clamping equipment/ jaws – except for markings applied by the manufacturer	K	4

Proposal for amendment

Add behind 1.3.6

1.3.x Isolated transverse cracks on the tread of wheels

1.3.x.1 without signs of thermal overload => K + R1 (isolate brake)

1.3.x.2

With signs of thermal overload (1.18) – detach wagon

Amendments to the GCU 2019 highlighted in yellow

3. Proposal for amendments in standards and regulation

3.8 Proposal for GCU amendments – **handling of thermally overloaded wheels** (04/10)

Appendix 9, Annex 1: Technical Conditions for Wagon Transfers between Railway Undertakings

GCU 2019

Proposal for amendment

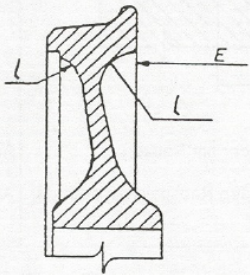
Component	Code no.	Irregularities/Criteria/Notes	Action to be taken	Category
Wheelset	1.7 1.7.1	<p>Clearance E between internal faces non-compliant with the following limit values:</p> <ul style="list-style-type: none"> – $\varnothing > 840 \text{ mm}$ 1357 mm $\leq E \leq$ 1363 mm – $\varnothing \leq 840 \text{ mm}$ 1359 mm $\leq E \leq$ 1363 mm <p>If in all cases, $E_{\text{max}} - E_{\text{min}} > 2 \text{ mm}$</p> <ul style="list-style-type: none"> • signs of derailment • signs of movement of wheel on axle • heating (solid wheel) in "L" fillet zone between web and rim/tyre 	Detach wagon	5

No amendment necessary

Amendments to the GCU 2019 highlighted in yellow

3. Proposal for amendments in standards and regulation

3.8 Proposal for GCU amendments – handling of thermally overloaded wheels (05/10)

Appendix 9, Annex 5: Technical Conditions for Wagon Transfers between Railway Undertakings

GCU 2019

Proposal for amendment

1.2.2.1		Tyre (solid wheel), except wheels marked as able to withstand high thermal stresses	No thermal overload due to braking, tolerance range not exceeded	VC, M	4
1.2.2.2		Tyre (solid wheel), except wheels marked as able to withstand high thermal stresses	No thermal overload due to braking, tolerance range not exceeded	VC, M	5

No amendment necessary

Amendments to the GCU 2019 highlighted in yellow

3. Proposal for amendments in standards and regulation

3.8 Proposal for GCU amendments – handling of thermally overloaded wheels (06/10)

Appendix 9, Annex 8: Technical Conditions for Wagon Transfers between Railway Undertakings

GCU 2019

3. With wheels displaying the criteria for thermal overload as per no. 1.2.2

For wheels displaying indications of thermal overload as per no. 1.2.2 and not being marked as being able to withstand high thermal stresses, measure the widening of the inner faces (E value) at the running surface of the rail at 3 distant points of 120° and verify no. 1.7.1

Establish the traceability of Annex 12.

(Annex 12 = sheet for Registration of axle data for operating wagon)

Proposal for amendment

For wheels displaying indications of thermal overload as per no. 1.2.2 and not being marked as being able to withstand high thermal stresses:

- measure the widening of the inner faces (E value) at the running surface of the rail at 3 distant points of 120° and verify no. 1.7.1
- Control isolated transverse cracks on the tread
- Establish the traceability of Annex 12.

Amendments to the GCU 2019 highlighted in yellow

3. Proposal for amendments in standards and regulation

3.8 Proposal for GCU amendments – handling of thermally overloaded wheels (07/10)

Appendix 10: Wagons – Corrective and Preventive Maintenance), point 1.18

GCU 2019

Proposal for amendment

See next slide

- 1.18 Monobloc wheels may not display marks of thermal overload caused by the brake:
- a paint burn of 50 mm or more at the connection between the rim and wheel centre or recent traces of rust on the tyre (unpainted wheels) or
 - fusion of brake blocks or
 - deterioration of wheel tread with build-up of metal.

If thermal overload is suspected, a brake test must be performed in accordance with UIC Leaflet 543-1 and the keeper must be consulted in order to obtain instructions. If the keeper does not provide instructions, the wheelsets concerned must be replaced using Form H^R.

VERSION: 1ST OF JANUARY, 2019

7

GENERAL CONTRACT OF USE FOR WAGONS

APPENDIX 10

Wheels that are able to withstand high thermal stresses and which are marked on the cover of the axle-box casing with an interrupted vertical white line (Appendix 11, point 6.1) are exempt from the measures listed above.

Amendments to the GCU 2019 highlighted in yellow

3. Proposal for amendments in standards and regulation

3.8 Proposal for GCU amendments – handling of thermally overloaded wheels (08/10)

Appendix 10: Wagons – Corrective and Preventive Maintenance, point 1.18

Proposal for amendment

1.18 Monobloc wheels may not display marks of thermal overload caused by the brake:

- clearly burnt paint at connection between rim and wheel plate (paint cracked/ peeled)
- traces of rust at connection between rim and wheel plate
- fusion of brake blocks
- deterioration of wheel tread with build-up of metal (see also no. 1.3.4)
- rim not uniformly bluish colored from overheating
- protruding (flanging) brake blocks

If thermal overload is suspected, a brake test must be performed in accordance with UIC Leaflet 543-1 and on the wheels the measures for thermally overloaded wheels ¹⁾ has to be performed. If this is not directly possible and the keeper does not provide additional instructions, the wheelsets concerned must be replaced using Form HR.

Wheels that are able to withstand high thermal stresses and which are marked on the cover of the axle-box casing with an interrupted vertical white line (Appendix 11, point 6.1) are exempt from the measures listed above.

The burnt paint must not be renewed, except the traceability to the keeper is guaranteed. (special GCU code)

¹⁾ Note:

Information for the keeper - Measures on thermally overloaded wheels:

- Residual stress measurement*
- Measurement back to back distance between the wheels
- Reprofiling
- NDT of the tread*

* alternative: systematic reprofiling of large depth in diameter and visual inspection of the tread according to service experience

Amendments to the GCU 2019 highlighted in yellow

3. Proposal for amendments in standards and regulation

3.8 Proposal for GCU amendments – handling of thermally overloaded wheels (09/10)

Appendix 10: Wagons – Corrective and Preventive Maintenance

GCU 2019

3.6 If wagons have protruding brake blocks, it is necessary to eliminate the cause of the protrusion after consultation with the keeper and after he has given instructions. If it is not possible to remedy the cause the wagon must be dealt with in accordance with Appendix 9. A brake block shall be considered protruding if, when it is applied, its external face reaches the external face of the rim.

Proposal for amendment

If wagons have protruding (flanging) brake blocks, it is necessary to eliminate the cause of the protrusion after consultation with the keeper and after he has given instructions. If it is not possible to remedy the cause the wagon must be dealt in accordance with Appendix 9. A brake block shall be considered protruding if, when it is applied, its external face reaches the external face of the rim.

In case of protruding brake blocks, the wheels have to be checked against marks of thermal overload as per point 1.18 of this Appendix 10.

Amendments to the GCU 2019 highlighted in yellow

3. Proposal for amendments in standards and regulation

3.8 Proposal for GCU amendments – handling of thermally overloaded wheels (10/10)

Appendix 10: Wagons – Corrective and Preventive Maintenance

GCU 2019

Proposal for amendment

- 1.30 Wagons with load-proportional tread brakes for running under SS conditions may not be fitted with monobloc wheels of steel grades R2, R3, R8 or R9.
If thermal overloading is suspected, the provisions of point 1.18 shall apply.

No amendment necessary

Amendments to the GCU 2019 highlighted in yellow

4. Complementary investigation and activities

4.1 Definition of assessment/ Product requirements for thermo-sensitive paint (1/2)

Result	Definition of assessment/ Product requirements for thermo-sensitive paint
Motivation/ reason	<ul style="list-style-type: none">• The cracks in the rim were thermally initiated. An improved detection of thermally overloaded wheelsets reduce the probability of failure.
Proposed place/ way for implementation	<ul style="list-style-type: none">• Final definition of the requirements and implementation• Implementation in EN 13 262 - Wheelsets and bogies — Wheels — Product requirements
To apply	<ul style="list-style-type: none">• -
Responsible for implementation in official references	<ul style="list-style-type: none">• CEN WG 11 (JNS/JSG)

Preliminary proposal for definition of assessment/ Product requirements for thermo-sensitive paint:

- Test on basis of the drag braking test in accordance EN 13 979-1/ UIC 510-5
- Temperature for reaction of the paint: 250 – 300°C
- Verification procedure based on known thermo-sensitive coating (e.g. the ones mentioned in ECM documents like VPI 04)

4. Complementary investigation and activities

4.1 Definition of assessment/ Product requirements for thermo-sensitive paint (2/2)

To define:

- Test with wheel accordance UIC 510-5 or metal plate heating up in furnace or burner
- Boundary conditions, like roughness and treatment of the wheel and thickness of the paint
- if needed: heating up ramp necessary (e.g. 15 min 200°, 15 min 250°, 15 min 300° with each 5 min heating up time)

Conditions for the reaction of the paint

Paint shall be clearly burnt => paint in this area shall present cracks/ peeling / bubbles (no direct dispersion)

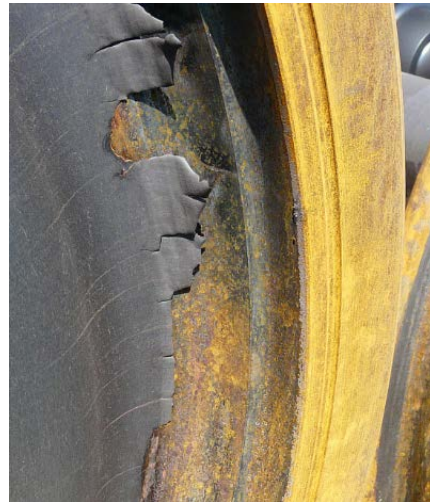

4. Complementary investigation and activities

4.2 Clear application of s/ss/ **/***

Result	Different interpretation possible for wording in UIC and TSI WAG for: <ul style="list-style-type: none">• maximum permitted braked weight per wheelset for ** and *** marked waggon• Marking with stars
Motivation/ reason	<ul style="list-style-type: none">• Regulation for the application axle load – maximum speed – marking of the speed are defined in TSI and UIC leaflets with complex wording => different interpretation possible
Proposed place/ way for implementation	Recommendation: clear and harmonized wording in TSI WAG and UIC 543
To apply	<ul style="list-style-type: none">• All
Responsible for implementation in official references	<ul style="list-style-type: none">• JNS/ JSG/ UIC

4. Complementary investigation and activities

4.3 Application of the best practice brake method

Result	<ul style="list-style-type: none">• Application of the best practice brake method (e.g. saw cut method) to reduce inhomogeneities in brake energy distribution in the train<ul style="list-style-type: none">• Collection based on available documents (e.g. UIC reports)• Definition way of publication (how/ where)? e.g. TSI operation?
Motivation/ reason	<ul style="list-style-type: none">• Reduce thermal overload of brake and wheel• Reduce inhomogeneities in the train
Proposed place/ way for implementation	<ul style="list-style-type: none">• Next steps:<ul style="list-style-type: none">• Collection and summary of the information• Publishing in TSI OPE?
To apply	<ul style="list-style-type: none">• (RU)
Responsible for implementation in official references	<ul style="list-style-type: none">• JNS/ JSG/ UIC• ERA

4. Complementary investigation and activities

4.4 Sector project proposal “Brake block wheel interaction” (1/2)

Result	<ul style="list-style-type: none">• Support of the sector project proposal “Brake block wheel interaction”
Motivation/ reason	<ul style="list-style-type: none">• The current state of the art for the design of the wheels and the braking system may not take into account all of the operational aspects. For the further development of the assessment of the wheels detailed investigation of the system interaction in real operation are recommended.• List of open points: see next slide
Proposed steps	<ul style="list-style-type: none">• Distribution by the sector organization• Participation / and financing of the project by the organization• Financing by EU with the support of ERA
To apply	<ul style="list-style-type: none">• All
Responsible for implementation in official references	<ul style="list-style-type: none">• Result of the project

4. Complementary investigation and activities

4.4 Sector project proposal “Brake block wheel interaction” (2/2)

List of open points:

- general requirements for brake and wheel are defined, worst case for the wheel not analyzed in detail (e.g. stop braking versus drag braking, extraordinary service conditions)
- Product requirements for brake block (UIC+ EN Standard)
- Braking Inhomogeneity (e.g. efficiency, brake block types, wagon types, material parameter, friction coefficient), operational behavior of the products
- Improvement of design requirements
 - Worst case scenario, e.g. combination between thermal load and mechanical load
 - Improvement of the thermomechanical calculation (based e.g. on UIC B 169/ RP 17)
 - Definition of the design type and assessment process between wheel types
- Residual stress threshold for the wheel test
- New tolerance range for friction coefficient in UIC 541-4
- Thermal conductivity for calculation and assessing serial test
- Analysis of the influence of environmental effects and the wheel / rail contact to the resulting temperature in the wheel (linked with star marking)

4. Complementary investigation and activities

4.5 Follow up of JNS normal procedure

Result	The JNS TF propose a follow up of the JNS normal procedure “Broken wheels” until at least GCU amendment (2022)
Motivation/ reason	<ul style="list-style-type: none">• Exchange of information between all Sector partners including ERA and NSA to improve the safety culture and avoid national measures and to keep interoperability• Collection Feedback from measures JNS final report “Broken wheels• Follow up of to the sector project proposal• Updating of the GCU and standardization process• Monitor the status of the implementation of the long term measures• If necessary – analyze of new cases based on information collected through “Template_for_analysis_cracked_wheels.xlsx”
Proposed working principle:	<ul style="list-style-type: none">• Use of the email distribution list for sharing information• Interchange of information inside JSG at least all 3 month (web conference or physical meeting)• Interchange of information inside JNS two times per year (web conference or physical meeting)
To apply	<ul style="list-style-type: none">• All

5. Background information

Reference “single cracks on the wheel tread”

Description: The tread exhibits cracks at an angle of approximately 90° to the circumference of the wheel and have a typical length of 30mm or more. Transverse cracks generally develop at the surface in either straight or slightly crooked lines and can penetrate radially (usually of thermal origin in these cases) or branch out in a circumferential direction (usually of mechanical origin in this case). They occur individually and can be distributed at several points around the circumference. [EN 15313, §C.2.6]

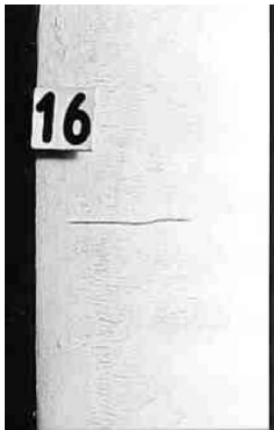

Transverse crack revealed by magnetic particle testing [EN 15313, §C.2.6]



Example for single cracks on the wheel tread by visual inspection

5. Background information

Reference “Thermal overload of the wheel” (1/2)

Description: This type of defect occurs only in tread-braked wheels. When suitable coatings are used, the paint becomes clearly burnt in the rib/web transition radius when the temperature exceeds approximately 300 °C. The paint in this area then becomes cracked and peeling. The brake blocks are often melted to some extent. Build-up of metal and characteristic colouring can be seen on the tread. The rim may also become a bluish colour.

If the problem is not detected immediately the rim/web transition can gradually assume a rusty appearance with shades between greyish-brown and brown covering the whole circumference. [EN 15313, §C.3.2.2]



Overheating affecting the wheel rim/web transition [EN 15313, §C.3.2.2]



Old and fresh burnt paint

Flanging brake blocks may be an indication of thermal overload.

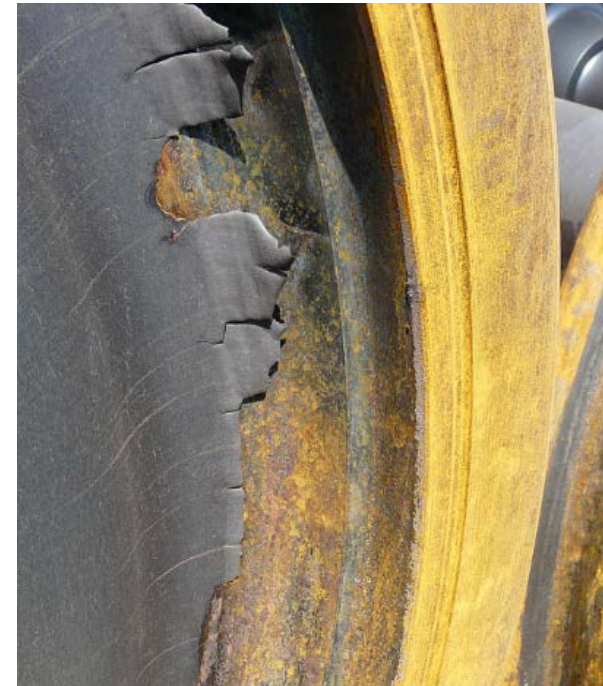

5. Background information

Reference "Thermal overload of the wheel" (2/2)



colouring on the tread



Metal build up on the tread



Melted brake block

5. Background information

Hammer/ Sound – test of the wheels (1/2)

Wheel with cracks from the rim in the web

- A wheel with cracks from the rim to the web can be detected by sound test independently from the position of the cracks over the circumference. The wheel response with a thud like sound.
- Defects on the tread (without crack to the web) can't be detected
- Uncracked wheel response with a ringing sound independently from the wheel type (web shape) and wheel diameter.

Preconditions for the hammer/ sound test

- The test should to be done between 2 and 5 or 7 and 11o' clock around the circumference.
- The test can be done on the tread or the outer sides of the rim.
- The test can be done with a regular hammer with short handle or with a special hammer with long handle for the waggon inspector. For ergonomically reasons a long handle is recommended.

5. Background information

Hammer/ Sound – test of the wheels (2/2)

Misleading test results

- The test on the 12 o'clock position (upper position of the wheel) sounds always thud/ damped.
- Wheelsets with applied brake blocks or not fully released brake blocks sound also thud/ damped. In this case the full release of the brake blocks has to be checked.
- In case of a thud / damped sounding wheel it is necessary to inspect the whole wheel more carefully.



Conclusion

Hammer/ sound test can be adapted in special cases as additional method to detect cracked rim/ broken wheels.

6. Summary JNS Task Force “Broken wheels”

General

In 2016/2017 broken and cracked wheels BA 314 / ZDB29 (with a slope under the wheel flange) and BA004 in some application in the European freight business occurred.

To mitigate the risk on 28th July 2017 short term measures in operation, wagon maintenance and off vehicle wheelset maintenance were implemented.

In the second phase the Joint Network Secretariat Task Force “Broken wheels” – normal procedure performed in-depth analysis.

The present document replace and updates the short term mitigation measures and defines long-term measures and proposal for updating the standards and regulation or contractual requirements.

crack in the web

BA314 / ZDB29 (with a slope under the wheel flange)

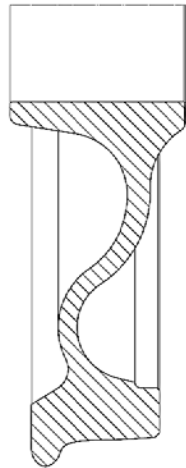

crack in the rim

BA 004

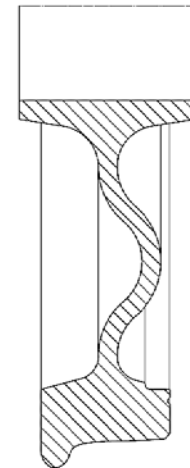

6. Financial impact JNS Task Force “Broken wheels”

Rough cost estimation

Responsible	Measures	Assumption for estimation (depends on ECM and application)	Cost estimation in the whole sector
RU	No additional measures	5.000 additional wagons (wheelsets) to sort out from service a 100€	500.000 €
For ECM/Keeper	Risk assessment	20.000 € per ECM Number of ECM: 50	1.000.000 €
For affected ECM/ Keeper	Additional measures	100 € per wheelset / year 200.000 affected wheelsets	20.000.000 €
For affected application	Diameter reduction in affected application	75 € per 1 mm => 20 mm reduction => 1.500 € per wheelset 50.000 affected wheelsets	75.000.000 €

7. Summary JNS Task Force “Broken wheels” Implementation

1. Submission of JNS TF “Broken wheels” – Final Report to the JNS panel including explanatory letter
2. After endorsement by the JNS panel – dissemination of letter + final report by JNS secretariat:
 - to ERA for publication on the ERA website and distribution to ECM certification bodies (based on ERADIS)
 - to the Group of Representative Bodies (GRB) for the distribution to its members
 - to the official entities (OTIF, NIB Network, NSA Network) for the distribution to their members
 - to UIC for the distribution to its members
3. Specific distribution to the body “Responsible for implementation in official references” for proposal for amendments in standards and regulation:
 - For amendment in GCU: to GCU Joint committee by JSG
 - For amendment in EN: short summary by JSG => ERA
 - For amendment in TSI: TSI change request to be organized by GRB

7. Summary

Introduction and principles and Long term mitigation measures (1/1)

No.	Result	To apply by	Responsible for implementation in official references	See Slide
1.	I. Introduction and principles	all	all	3, 4, 5, 8
2.1 2.2	Operation and wagon maintenance	Affected ECM/ RU	-	9 - 10
2.3.	Off vehicle wheelset maintenance – BA 004	Affected ECM/ RU	-	11
2.4.	Off vehicle wheelset maintenance – BA 314/ZDB 29 with slope under rim	Affected ECM/ RU	-	12
2.5	Data collection after incidents of tread braked wheels	all	-	13

7. Summary

Proposal for amendments in standards and regulation (1/2)

No.	Result	To apply by	Responsible for implementation in official references	See Slide
3.1	General recommendation for the sector in respect of JNS	all	ERA/ NSA/ Sector	14
3.2	Improvement of the design of tread braked wheels - calculation	-	CEN WG 11	15
3.3	Improvement of the design of tread braked wheels - design recommendation	-	CEN WG 11	16
3.4	Distinction between different wheel geometries by own description	Wheel designer and manufacturer	CEN WG 11	17
3.5	Maintenance and operation: Measures after thermal overload of wheelsets	All ECM	CEN WG 11 GCU Joint Committee	18, 19

7. Summary

Proposal for amendments in standards and regulation (2/2)

No.	Result	To apply by	Responsible for implementation in official references	See Slide
3.6	Detection of thermally overloaded wheels – use of thermo-sensitive paint	All ECM	CEN WG 11	20
3.7	Application of the UIC guideline composite brake blocks	all	ERA with support of UIC SET 7 and CEN WG 47	21
3.8	Proposal for GCU amendments: handling of thermally overloaded wheels	all	GCU Joint Committee	22 - 31

7. Summary

Complementary investigation and activities (1/1)

No.	Result	To apply by	Responsible for implementation in official references	See Slide
4.1	Definition of assessment/ Product requirements for thermo-sensitive paint	-	CEN WG 11 (JNS/JSG)	32, 33
4.2	Brake - clear application of s/ss/ **/***	all	JNS/ JSG/ UIC ERA	34
4.3	Application of the best practice brake method	(RU)	JNS/ JSG/ UIC	35
4.4	Sector project proposal “Brake block wheel interaction”	All	Result of the project	36, 37
4.5	Follow up of JNS normal procedure “Broken wheels”	All	-	38