

**ANALYSIS OF THE BASIC PARAMETERS FOR  
MAINTAINING THE TECHNICAL AND  
OPERATIONAL COMPATIBILITY OF THE 1 520 mm  
AND 1 435 mm GAUGE RAIL SYSTEMS AT THE  
COMMONWEALTH OF INDEPENDENT STATES  
(CIS)-EUROPEAN UNION (EU) BORDER**

**SUBSYSTEM: INFRASTRUCTURE.  
PERMANENT WAY AND TRACK FACILITIES**

**Document prepared by the Contact Group of the Organisation for  
Cooperation between Railways (OSJD) and the European Railway Agency  
(ERA)**

**(Translation from the original in Russian)**

**JANUARY 2009**

**REVISIONS AND AMENDMENTS**

<b>Revision and date</b>	<b>Sections</b>	<b>Explanations</b>	<b>Author</b>
0.01/ 18.03.08	All	Working document based on information received from the ERA prior to 01.03.08	FAD
0.02/ 28.03.08	All	Working document with the incorporation of comments made at the meeting of 28.03.08	FAD
0.03/ 20.05.08	2, 3, 5, 6, 7	Working document based on information received from the ERA prior to 20.05.08	FAD
0.04/ 28.05.2008	5	Working document with the incorporation of comments made at the meeting of 28.05.08	VK FAD
0.05/ 10.09.2008	1, 2, 3, 4, 5, 6	Working document based on information received from the ERA prior to 10.09/08	VK FAD
0.06/ 03.10.2008	2, 5, 6	Working document with the incorporation of comments made at the meeting of 03.10.08	VK FAD
0.07/ 10.12.2008	2, 3, 5.1.5, 5.2.6-5.2.8, 5.3.2, 5.4.2, 5.4.3, 5.5.1, 5.5.3, 5.6.1, 5.6.2, 5.7.5, 5.7.6, 5.8.3-5.8.6, 5.10, 5.10.2, 5.10.3, 5.10.6, 6.3.3, 6.6.2-6.6.4, 6.7.3-6.7.4, 6.8.4, 7	Preliminary draft for endorsement at a forthcoming meeting	VK FAD
1.00/ 27.01.2009	2, 3, 5, 5.1.5, 5.2.1, 5.4.1, 5.4.2, 5.5.1, 5.9.1, 5.10.3, 5.10.4, 5.10.5	Document endorsed by the contact group	VK
1.01/ 19.03.2009	Title of the document, 1	Addition “and 1435” according to a of decision of the Empowered representatives of members of Conference of Ministers of OSJD and Conference of Director Generals	VK FAD
1.02/ 08.03.2010	4	Clarification on the list of parameters (responsible representatives) of OSJD railways (9-11 Dec 2008, Warsaw)	FAD

## TABLE OF CONTENTS

1	SCOPE.....	7
2	REGULATORY (BASELINE) DOCUMENTS .....	8
3	DEFINITIONS AND ABBREVIATIONS .....	25
4	LIST OF BASIC PARAMETERS .....	30
5	ANALYSIS OF BASIC PARAMETERS .....	34
5.1	LINE LAYOUT .....	37
5.1.1	Minimum structure gauge .....	37
5.1.2	Distance between track centres .....	39
5.1.3	Maximum gradients .....	40
5.1.4	Minimum radius of horizontal curve.....	43
5.1.5	Minimum radius of vertical curve.....	44
5.1.6	Length of station entry and deparure tracks .....	46
5.2	TRACK PARAMETERS .....	47
5.2.1	Nominal gauge .....	47
5.2.2	Cant .....	50
5.2.3	Cant deficiency .....	51
5.2.4	Rate of change of cant.....	52
5.2.5	Railhead profile (for plain line).....	55
5.2.6	Equivalent conicity .....	57
5.2.7	Rail inclination.....	57
5.2.8	Track Stiffness .....	58
5.2.9	Electrical insulation of rails .....	60
5.3	REQUIREMENTS FOR SWITCHES AND CROSSINGS .....	61
5.3.1	Means of Locking .....	61
5.3.2	In service geometry of switches and crossings .....	62
5.3.3	Maximum unguided length of fixed obtuse crossings .....	70

5.4	TRACK RESISTANCE TO APPLIED LOADS.....	71
5.4.1	Track resistance to vertical loads .....	71
5.4.2	Longitudinal track resistance .....	72
5.4.3	Lateral track resistance.....	74
5.5	STRUCTURES RESISTANCE TO TRAFFIC LOADS.....	76
5.5.1	Resistance of bridges to traffic loads .....	76
5.5.2	Equivalent vertical loading for earthworks and earth pressure effects .....	78
5.5.3	Resistance of structures over or adjacent to tracks .....	79
5.6	TRACK GEOMETRICAL QUALITY AND DEFECTS LIMITS ON ISOLATED SECTIONS .....	80
5.6.1	Determination of immediate action, intervention, and alert limits.....	80
5.6.2	Immediate action limit for track twist.....	81
5.6.3	The immediate action limit for variation of track gauge.....	82
5.6.4	Immediate action limit for cant .....	84
5.7	PLATFORMS.....	85
5.7.1	Usable length of platforms .....	85
5.7.2	Width and edge of platforms.....	87
5.7.3	Height of Platforms (high and low) .....	88
5.7.4	Offset of platforms .....	90
5.7.5	Characteristics of platforms linked to the access of people with reduced mobility .....	91
5.7.6	Width and edge of platforms (end of platforms).....	92
5.8	HEALTH, SAFETY AND ENVIRONMENT .....	93
5.8.1	Maximum pressure variation in tunnels.....	93
5.8.2	Piston effects in underground stations .....	93
5.8.3	Noise and vibration limits and mitigation measures .....	93
5.8.4	Protection against electric shock.....	95
5.8.5	Safety in railway tunnels.....	96
5.8.6	Effect of crosswinds.....	99

5.9	PROVISION FOR OPERATION .....	100
5.9.1	Distance markers .....	100
5.10	FIXED INSTALLATIONS FOR SERVICING TRAINS .....	101
5.10.1	Toilet discharge .....	103
5.10.2	Train external cleaning facilities .....	104
5.10.3	Water restocking .....	106
5.10.4	Sand restocking .....	108
5.10.5	Refuelling .....	111
5.10.6	Electric shore supply .....	113
6	COMPARISON WITH TARGET VALUES OF 1435 MM GAUGE SYSTEMS .....	116
6.1	TRACK PARAMETERS .....	116
6.1.1	Minimum structure gauge .....	116
6.1.2	Distance between track centres .....	116
6.1.3	Maximum gradients .....	116
6.1.4	Minimum radius of horizontal curve.....	117
6.1.5	Minimum radius of vertical curve.....	117
6.1.6	Length of station entry and deparure tracks .....	117
6.2	TRACK PARAMETERS .....	118
6.2.1	Gauge .....	118
6.2.2	Cant .....	118
6.2.3	Cant deficiency .....	118
6.2.4	Rate of change of cant.....	119
6.2.5	Railhead profile for plain track .....	120
6.2.6	Equivalent conicity .....	120
6.2.7	Rail inclination.....	120
6.2.8	Track stiffness .....	120
6.2.9	Electric Insulation of Rails.....	120

6.3	SWITCHES AND CROSSINGS .....	121
6.3.1	Means of locking.....	121
6.3.2	In service geometry of switches and crossings .....	121
6.3.3	Maximum unguided length of fixed obtuse crossings .....	123
6.4	TRACK RESISTANCE TO APPLIED LOADS.....	123
6.4.1	Track resistance to vertical loads .....	123
6.4.2	Longitudinal track resistance .....	124
6.4.3	Lateral track resistance.....	124
6.5	STRUCTURES RESISTANCE TO TRAFFIC LOADS.....	124
6.5.1	Resistance of bridges to traffic loads .....	124
6.5.2	Equivalent vertical loading for earthworks and earth pressure effects .....	125
6.5.3	Resistance of structures over or adjacent to tracks .....	125
6.6	TRACK GEOMETRICAL QUALITY AND DEFECTS LIMITS ON ISOLATED SECTIONS .....	125
6.6.1	Determination of immediate action, intervention, and alert limits.....	125
6.6.2	Immediate action limit for track twist.....	125
6.6.3	Immediate action limit for variation of track gauge.....	125
6.6.4	Immediate action limit for cant.....	125
6.7	PLATFORMS.....	126
6.7.1	Usable length of platforms .....	126
6.7.2	Width and edge of platforms.....	126
6.7.3	Height of platforms (high and low).....	126
6.7.4	Offset of platforms .....	126
6.7.5	Characteristics of platforms linked to the access of people with reduced mobility .....	127
6.7.6	End of platforms.....	127
6.8	HEALTH, SAFETY AND ENVIRONMENT .....	127
6.8.1	Maximum pressure variation in tunnels.....	127
6.8.2	Piston effects in underground stations .....	127

6.8.3	Noise and vibration limits and mitigation measures .....	128
6.8.4	Protection against electric shock.....	128
6.8.5	Safety in railway tunnels.....	128
6.8.6	Effect of crosswinds.....	129
6.9	PROVISION FOR OPERATION.....	129
6.9.1	Distance markers.....	129
6.10	FIXED INSTALLATIONS FOR SERVICING TRAINS .....	129
6.10.1	Toilet discharge.....	129
6.10.2	Train external cleaning facilities.....	130
6.10.3	Water restocking .....	130
6.10.4	Sand restocking.....	130
6.10.5	Refuelling.....	130
6.10.6	Electrical shore supply .....	131
7	ANNEXES .....	132
7.1	MEMBERS OF CONTACT GROUP .....	132
7.2	MATTERS FOR FURTHER STUDY .....	132

## 1 SCOPE

The present document was prepared by the joint contact working group of experts of the ORGANISATION FOR COOPERATION BETWEEN RAILWAYS (hereinafter the OSJD) and the EUROPEAN RAILWAY AGENCY (hereinafter the ERA) (hereinafter the CONTACT GROUP) as part of cooperation between these organisations in analysing the interoperability of rail systems both inside and outside of the EU with a track gauge of 1 520 mm (1 524 mm for Finland) pursuant to a Memorandum of Understanding signed in 2008.

The OSJD performed this work pursuant to its plan of action for 2008 and subsequent years.

The ERA performed this work pursuant to section 4.10 (Interconnection to a 1 520/1 524-mm Rail System) of the Mandate received by the Agency for Drafting a Third Group of Technical Specifications for Interoperability (TSI).

The contact group performed an analysis of the existing technical specifications for the Infrastructure subsystem (Permanent Way and Track Facilities) of the 1 520 mm gauge rail system and identified the determinative parameters for maintaining the compatibility of the 1 520 mm gauge rail system at the CIS-EU border. The analysis was confined to technical and operational aspects of the railway system. This analysis does not include high-speed traffic (in excess of 200 kilometres (km) per hour).

This document contains the technical requirements for the aforementioned parameters established by the regulatory acts currently applicable within the 1 520 space and draws a comparison between these requirements and the target values established for the basic parameters of a 1 435-mm gauge rail system by the draft Infrastructure TSI created pursuant to the Directive on the Interoperability of the European Conventional Rail System.

The language of this document is intended to reflect and to generalise, insofar as possible, the technical requirements currently in effect in different nations. The terms used in this document shall not serve as regulatory references. The documents cited in section 2 should be used for more precise statements of the requirements.

The materials (technical information) in this document may serve as the basis for reflecting the 'basic parameters' of the 1 520 mm system in the EU TSI for the purpose of preserving the existing technical compatibility of the 1 520 mm system at the CIS-EU border.



## 2 REGULATORY (BASELINE) DOCUMENTS

[No] Short document title	Full document title and document availability
[1.] <b>International/interstate documents</b>	
[1.1.] Construction Norms and Regulations (SNiP) II-39-76 '1 520 mm Gauge Railways'	SNiP II-39-76 '1 520 mm Gauge Railways'. This document is only used for information purposes in Latvia and the Ukraine
[1.2.] SNiP III-44-77 'Work Performance and Acceptance Rules. Railway and Hydraulic-Engineering Tunnels. Underground Railways'	SNiP III-44-77 'Work Performance and Acceptance Rules. Railway and Hydraulic-Engineering Tunnels. Underground Railways'
[1.3.] SNiP II-44-78 'Railway and Highway Tunnels'	SNiP II-44-78 'Railway and Highway Tunnels'
[1.4.] SNiP III-4-80 'Construction Safety'	SNiP III-4-80 'Construction Safety'
[1.5.] SNiP 2.05.03-84 'Bridges and Tubes'	SNiP 2.05.03-84 'Bridges and Tubes'
[1.6.] SNiP 32-01-95 '1 520 mm Gauge Railways'	SNiP 32-01-95 '1 520 mm Gauge Railways'
[1.7.] SNiP 32-04-97 'Railway and Highway Tunnels'	SNiP 32-04-97 'Railway and Highway Tunnels'
[1.8.] SNiP II-D.7-62 'Bridges and Tubes. Design Rules'	SNiP II-D.7-62 'Bridges and Tubes. Design Rules'
[1.9.] GOST 8161-75 'R65 Type Railway Rails. Design and Dimensions'	State Standard (GOST) 8161-75 'R65 Type Railway Rails. Design and Dimensions'
[1.10.] GOST 12.1.019-79 'Electrical Safety. General Requirements and Types of Protection'	GOST 12.1.019-79 'Electrical Safety. General Requirements and Types of Protection'
[1.11.] GOST 12.0.002-80 'Occupational Safety Standards System. Terms and Definitions'	GOST 12.0.002-80, Interstate Standard. Occupational Safety Standards System. Terms and Definitions
[1.12.] GOST 9238-83 '1 520 (1 524) mm Gauge Railway Minimum Gauges for Structures and Rolling Stock'	GOST 9238-83 '1 520 (1 524) mm Gauge Railway Minimum Gauges for Structures and Rolling Stock. Specifications'
[1.13.] GOST 12.1.003-83 'Noise. General Safety Requirements'	GOST 12.1.003-83 'Noise. General Safety Requirements'
[1.14.] GOST 2593-82 'Coupling Hose Pipes for Railway Rolling Stock Brakes. Specifications'	GOST 2593-82 'Coupling Hose Pipes for Railway Rolling Stock Brakes. Specifications'

<b>[No] Short document title</b>	<b>Full document title and document availability</b>
[1.15.] GOST 22780 'Axles for 1 520 (1 524) mm Gauge Railway Vehicles. Types, Parameters, and Sizes'	GOST 22780 'Axles for 1 520 (1 524) mm Gauge Railway Vehicles. Types, Parameters, and Sizes'
[1.16.] GOST 2874-82 'Potable Water. Hygienic Requirements and Quality Control'	GOST 2874-82 'Potable Water. Hygienic Requirements and Quality Control'
[1.17.] Central Order (TsP)-4425 Instructions on Application of Minimum Structure Gauges	Department of Tracks and Facilities document TsP-4425 Instructions on Application of Minimum Structure Gauges
[1.18.] GOST 2761-84 'Sources of Centralised Household Drinking Water Supply. Hygienic and Technical Requirements, and Sampling Rules'	GOST 2761-84 'Sources of Centralised Household Drinking Water Supply. Hygienic and Technical Requirements, and Sampling Rules'
[1.19.] GOST 305 – Diesel Fuel	GOST 305 – Diesel Fuel
[1.20.] 'Instructions of the Ministry of Railways (MPS) of the Union of Soviet Socialist Republics (USSR). TsP-2913 Dated 8 June 1971'	'Instructions of the MPS of the USSR. TsP-2913 Dated 8 June 1971'
[1.21.] Official Construction Standards (VSN) 56-78 Instructions on Designing Stations and Railway Junctions of the USSR	VSN 56-78 'Instructions on Designing Stations and Railway Junctions of the USSR'
[1.22.] VSN 207-89, Rules and Regulations for Design of Marshalling Facilities on the Railways of the USSR	VSN 207-89 Rules and Regulations for Design of Marshalling Facilities on the Railways of the USSR
[1.23.] EN 13674-1:2003 Vignole Railway Rails of 46 Kilograms (kg) per Metre (m) and Above	EN 13674-1:2003, Railway Applications. Track. Rail. Vignole Railway Rails of 46 kg/m and Above
[1.24.] PN-EN 13146-1:2003 (U): PN-EN 13481-2:2004, Method for Inspecting Fastening Systems, Part 1	PN-EN 13146-1:2003 (U): PN-EN 13481-2:2004, Method for Inspecting Fastening Systems, Part 1. (Określenie oporu podłużnego szyny)
[1.25.] EN 1991-2:2003. Eurocode 1: Action on Structures – Part 2. Traffic Loads on Bridges	EN 1991-2:2003. Eurocode 1: Action on Structures – Part 2. Traffic Loads on Bridges
[1.26.] prEN 13803-1 Railway Applications – Track – Track Alignment Design Parameters – Track Gauges of 1 435 mm and Wider – Part 1: Plain Line	prEN 13803-1 Railway Applications – Track – Track Alignment Design Parameters – Track Gauges of 1 435 mm and Wider – Part 1: Plain Line

<b>[No] Short document title</b>	<b>Full document title and document availability</b>
[1.27.] NBN EN 13481-2, Railway Applications – Track – Performance Requirements for Fastening Systems – Part 2: Fastening Systems for Concrete Sleepers	[1.28.] NBN EN 13481-2, Railway Applications – Track – Performance Requirements for Fastening Systems – Part 2: Fastening Systems for Concrete Sleepers
[1.29.] BPC No. 4137-86 Labour Hygiene Classification	BPC No. 4137-86 Methodological Recommendations for Attestation of Workplace Working Conditions. Labour Hygiene Classification
[1.30.] Guidelines for Determining the Load-Bearing Capacity of the Metal Spans of Railway Bridges	Guidelines for Determining the Load-Bearing Capacity of the Metal Spans of Railway Bridges (approved by the Central Track Administration of the MPS of the USSR on 2 August 1985)
[1.31.] 'Automation and Remote Control Devices on Railway Vehicles, Departmental Process Design Standards (VNTP)/MPS-85'	Industry Technological Design Standards 'Automation and Remote Control Devices on Railway Vehicles, VNTP/MPS-85'
[1.32.] 30.07.1978. Order No. 27TsZ of the MPS USSR 'On the Design of Standard Permanent Reduce Speed Signs, Portable Signals, and Markers and Track Signs'	30.07.1978. Order No. 27TsZ of the MPS USSR 'On the Design of Standard Permanent Reduce Speed Signs, Portable Signals, and Markers and Track Signs'
[1.33.] TsTD-5 Sand for Locomotive Sanding Gear	TsTD-5 Sand for Locomotive Sanding Gear. Specifications
[1.34.] AGC	No. 26540. European Agreement on Main International Railway Lines (AGC). United Nations (UN), Economic Commission for Europe, Inland Transport Committee. Geneva, 31 May 1985
[1.35.] OSJD Leaflet O+R 563 'Solutions and Recommendations for the Standardisation of Sanitation Facilities in Passenger coaches', 2 <sup>nd</sup> edition	OSJD Leaflet O+R 563 'Solutions and Recommendations for the Standardisation of Sanitation Facilities in Passenger coaches', 2 <sup>nd</sup> edition
[1.36.] UIC Leaflet 552 and OSJD Leaflet O+R 556 'Train Electricity Supply, Including Electric Heating'	UIC Leaflet 552 and OSJD Leaflet O+R 556 'Train Electricity Supply, Including Electric Heating'

<b>[No] Short document title</b>	<b>Full document title and document availability</b>
[1.37.] UIC Leaflet O+R 554-1 'Power Supply to Electrical Equipment on Stationary Railway Vehicles (220 V, 380 V, 50 Hz)'	UIC Leaflet O+R 554-1 'Power Supply to Electrical Equipment on Stationary Railway Vehicles (220 V, 380 V, 50 Hz)'
[1.38.] OSJD Leaflet O-500 'Structure and Loading Gauges'	OSJD Leaflet O-500 Structure and Loading Gauges
[1.39.] OSJD Leaflet R-500/1, 'Recommendations for Compiling and Maintaining Data on Railway Route Passability by Structure Gauge and Permissible Axle Load per Linear Metre of Track'	OSJD Leaflet R-500/1, Recommendations for Compiling and Maintaining Data on Railway Route Passability by Structure Gauge and Permissible Axle Load per Linear Metre of Track
[1.40.] OSJD Leaflet R-500/2 'Uniform Instructions on Application of 0-T and 01-T Loading Gauges'	OSJD Leaflet R-500/2 Uniform Instructions on the Use of Rolling Stock 0-T and 01-T Clearances
[1.41.] OSJD Leaflet R-500/3 'Uniform Instructions on Application of Structure Gauges of the 1 435-mm Gauge Railways of OSJD Member Countries'	OSJD Leaflet R-500/3 Uniform Instructions on Application of Structure Gauges of the 1 435-mm Gauge Railways of OSJD Member Countries
[1.42.] OSJD Leaflet R-500/4 'Dynamic Envelope of Rolling Stock Based on the 0-T and 0-2T Loading Gauges of the Railways of OSJD Member Countries'	OSJD Leaflet R-500/4 Dynamic Envelope of Rolling Stock Based on the 0-T and 0-2T Loading Gauges of the Railways of OSJD Member Countries
[1.43.] OSJD Leaflet R-500/5 'Kinematic Method for Calculating Structure Gauge and Distances Between Track Centres'	OSJD Leaflet R-500/5 Kinematic Method for Calculating Structure Gauge and Distances Between Track Centres
[1.44.] OSJD Leaflet O-501 'Basic Requirements for Cars in International Traffic'	OSJD Leaflet O-501 Basic Requirements for Cars in International Traffic
[1.45.] OSJD Leaflet R-501/1 'Parameters and Basic Requirements for High-Speed Freight Cars'	OSJD Leaflet R-501/1 Parameters and Basic Requirements for High-Speed Freight Cars
[1.46.] OSJD Leaflet O-502 'Decision Concerning the Basic Conditions of Suitability of Type "B" Freight Cars for Ferry Transport'	OSJD Leaflet O-502 Decision Concerning the Basic Conditions of Suitability of Type 'B' Freight Cars for Ferry Transport

<b>[No] Short document title</b>	<b>Full document title and document availability</b>
[1.47.] UIC Leaflet 627-2 'Refuelling Equipment for Diesel Rolling Stock'	UIC Leaflet 627-2 'Refuelling Equipment for Diesel Rolling Stock'
[1.48.] Directive 2001/16/EC (Interoperability of Conventional Railways)	<p>Directive 2001/16/EC of the European Parliament and Council Dated 19 March 2001 on the Interoperability of the Trans-European Conventional Rail System</p> <p>Official Journal of the European Union (OJ L 110, 20.4.2001, pp. 1-27)</p> <p><a href="http://eur-lex.europa.eu/smartapi/cgi/sga_doc?smartapi!celexapi!prod!CELEXnumdoc&amp;numdoc=32001L0016&amp;model=guichett&amp;lg=en">http://eur-lex.europa.eu/smartapi/cgi/sga_doc?smartapi!celexapi!prod!CELEXnumdoc&amp;numdoc=32001L0016&amp;model=guichett&amp;lg=en</a></p>
[1.49.] Directive 2001/49/EC (Noise Level Assessment and Monitoring)	<p>Directive 2001/49/EC of the European Parliament and Council Dated 25 June 2002 on Noise Level Assessment and Monitoring</p> <p>Official Journal of the European Union (L 189, 18.07.2002)</p> <p><a href="http://eur-lex.europa.eu/LexUriServ/LexUriServ.do?uri=OJ:L:2002:189:0012:0025:EN:PDF">http://eur-lex.europa.eu/LexUriServ/LexUriServ.do?uri=OJ:L:2002:189:0012:0025:EN:PDF</a></p>
[1.50.] Directive 98/83/EC on Water Quality	Directive 98/83/EC of the Council Dated 3 November 1998 on the Quality of Water Intended for Human Use
[1.51.] Infrastructure TSI	Infrastructure TSI, draft
[1.52.] Locomotives, Traction Units, and Passenger coaches TSI	Locomotives, Traction Units, and Passenger coaches TSI, draft
[1.53.] Rolling Stock for High Speed Rail TSI	<p>Rolling Stock for High Speed Rail TSI</p> <p>COMMISSION DECISION Dated 30 May 2002 on the Technical Specification for Interoperability Relative to the Rolling Stock Subsystem of the Trans-European High-Speed Rail System referred to in Article 6(1) of Directive 96/48/EC</p>

<b>[No] Short document title</b>	<b>Full document title and document availability</b>
[1.54.] Persons with Reduced Mobility TSI	<p>TSI, Persons With Reduced Mobility (PRM) European Commission Decision 2007/164/EC Dated 21 December 2007 on the Specification of Technical Interoperability Relative to Persons With Reduced Mobility for Trans-European Conventional and High-Speed Railways</p> <p>(Notified Under Document C(2007) 6633), Text With European Economic Area (EEA) Relevance</p> <p>Official Journal, L 064 , 07.03.2008, pp. 0072-0207  <a href="http://eur-lex.europa.eu/LexUriServ/LexUriServ.do?uri=OJ:L:2008:064:0072:01:EN:HTML">http://eur-lex.europa.eu/LexUriServ/LexUriServ.do?uri=OJ:L:2008:064:0072:01:EN:HTML</a></p>
[1.55.] Rolling Stock Noise Level TSI	<p>European Commission Decision 200/66/EC Dated 23 December 2005 Concerning the Specification of Technical Interoperability Relative to the Rolling Stock Noise Level Subsystem for Trans-European Conventional and High-Speed Railways (Notified Under Document Number C(2005) 5666 ) (Text With EEA Relevance)</p> <p>Official Journal L 037, 08.02.2006, pp. 0001-0021  <a href="http://eur-lex.europa.eu/LexUriServ/LexUriServ.do?uri=OJ:L:2006:037:0001:01:EN:HTML">http://eur-lex.europa.eu/LexUriServ/LexUriServ.do?uri=OJ:L:2006:037:0001:01:EN:HTML</a></p>
[1.56.] Safety in Rail Tunnels TSI	<p>TSI on Safety in Railway Tunnels on the Trans-European Conventional and High-Speed Railway Network (Adopted Under the European Commission Resolution Dated 20 December 2007 (2008/164/EC))</p> <p>Official Journal of the European Union (L 64, 07.03.2008)  <a href="http://europa.eu.int/eur-lex/lex/JOHtml.do?uri=OJ%3AL%3A2008%3A064%3ASOM%3AEN%3AHTML">http://europa.eu.int/eur-lex/lex/JOHtml.do?uri=OJ%3AL%3A2008%3A064%3ASOM%3AEN%3AHTML</a></p>

<b>[No] Short document title</b>	<b>Full document title and document availability</b>
[1.57.] Track Engineer's Handbook, Volume I	'Track Engineer's Handbook, Volume I', <i>Transport Publishing House, Moscow, 1972.</i> A version is available in Lithuanian.
<b>[2.] Documents of the Republic of Belarus</b>	
[2.1.] PTE of the Belarusian Railway	Standard Operating Procedures (PTE) of the Belarusian Railway (approved under Order No 292N of the Head of the Belarusian Railway on 04.12.2002)
[2.2.] Enterprise Standards document (STP) 09150.56.010-2005 'Routine Railway Track Maintenance. Technical Requirements and Work Management'	STP 09150.56.010-2005, 'Routine Railway Track Maintenance. Technical Requirements and Work Management'
[2.3.] SNB 3.03.01-98 '1 520 mm Railways'	Belarusian Construction Standard SNB 3.03.01-98, '1 520 mm Railways'
[2.4.] Order Concerning the Procedure for Application of Certain Provisions of the Standard Operating Procedures, the Instructions on Signalling, Train Traffic and Shunting Operations on the Belarusian Railway	Concerning the Procedure for Application of Certain Provisions of the Standard Operating Procedures, the Instructions on Signalling, Train Traffic and Shunting Operations on the Belarusian railways (Order No 15N of the Head of the Belarusian Railway Dated 14.01.2003)
[2.5.] STP 09150.19.058-2007 'Maintenance Requirements for Signalling, Control, and Interlock Devices'	STP 09150.19.058-2007 'Maintenance Requirements for Signalling, Control, and Interlock Devices'
[2.6.] Standards for the Technological Design of Suburban Stations (VNTP No 78 of the MPS)	Standards for the Technological Design of Suburban Stations (VNTP No 78 of the MPS)
[2.7.] VSN-01-91 'Railway Stations for Through Service Passengers'	VSN-01-91 'Railway Stations for Through Service Passengers'
[2.8.] Order No 450N of the Head of the Belarusian Railway Dated 30.12.2006	Order No 450N of the Head of the Belarusian Railway Dated 30.12.2006
[2.9.] TsMV-2 Instructions on Operating Procedure and Safe Servicing of the PZh-2.5 Vacuum System on an FEH	TsMV-2 Instructions on Operating Procedure and Safe Servicing of the PZh-2.5 Vacuum System on an FEH
[2.10.] TsTChS-50 Instructions on Preparation and Use of Water to Cool Diesel Locomotives and Diesel Multiple-Unit Train Locomotives	TsTChS-50 Instructions on Preparation and Use of Water to Cool Diesel Locomotives and Diesel Multiple-Unit Train Locomotives

<b>[No] Short document title</b>	<b>Full document title and document availability</b>
[2.11.] TsT-940 Instructions on Use of Lubricants on Locomotives and Multiple-Unit Rolling Stock (MURS)	TsT-940 Instructions on Use of Lubricants on Locomotives and MURS
<b>[3.] Documents of the Latvian Republic</b>	
[3.1.] LVS 484-2008 'Railway Applications. Passenger Platforms on 1 520 mm Gauge Railway Lines'	Latvian State Standard LVS 484-2008 'Railway Applications. Passenger Platforms on 1 520 mm Gauge Railway Lines'
[3.2.] LVS 282-2005 'Structure and Loading Gauges'	LVS 282-2005 'Structure and Loading Gauges'
[3.3.] 'PTE of the Latvian Railway'	27.04.1999. Council of Ministers (CM) document 'Standard Operating Procedures, No 148
[3.4.] 'Instructions on Routine Track Maintenance'	1999, Latvian Railway Infrastructure Manager (LRW IM), 'Instructions on Routine Track Maintenance' (Instructions MPS USSR TsP-2913 dated 8 June 1971 was taken as the basis for creating this document)
[3.5.] SN 200-62 'Specifications for the Design of Railway, Highway, and Urban Bridges and Tubes'	SN 200-62 'Specifications for the Design of Railway, Highway, and Urban Bridges and Tubes'
[3.6.] Infrastructure Manager Technical Instructions No CEJ-7/185 dated 28.07.1998	Infrastructure Manager Technical Instructions No CEJ-7/185 dated 28.07.1998, 'Technical Instructions on Interpreting Rail Spotter Tapes for Elimination of Discrepancies in Track Maintenance and Action to Ensure Traffic Safety upon Detection'
[3.7.] DR-67/2004 'Instructions on Diesel Engine Cooling Fluid'	DR-67/2004 Instructions on Use and Quality Control of the Preparation of the Diesel Engine Cooling Fluid of Railway Traction Rolling Stock. Approved Under Directive No DV-3/403 of the First Deputy Chairman of the Latvian Railway Administrative Board Dated 24.09.2004
[3.8.] DR-72/2005 'Instructions on Sand Quality'	DR-72/2005 Instructions on Quality Control of the Sand in Locomotive and Multiple-Unit Rolling Stock Sanding Gear. Approved by the Director for Rolling Stock of the Latvian Railway on 12.07.2005.



<b>[No] Short document title</b>	<b>Full document title and document availability</b>
[3.9.] DR-77/2007 'Instructions on Lubrication'	DR-77/2007 Instructions on the Lubrication of Locomotives and Multiple-Unit Rolling Stock. Approved by the Director for Rolling Stock of the Latvian Railway on 15.01.2007
[3.10.] LVS EN 590 'Diesel Fuel'	LVS EN 590 Fuel for Internal Combustion Locomotives – Diesel – Requirements and Testing Techniques
[3.11.] Cabinet of Ministers Regulations No 566	Cabinet of Ministers Regulations No 566 dated 29.06.2004 titled 'Method for Dividing Railway Infrastructure of Strategic and Regional Significance into Categories'
[3.12.] SP 32-104-98 'Designing the Roadbed of 1 520 mm Gauge Railways'	Building Regulations SP 32-104-98 'Designing the Roadbed of 1 520 mm Gauge Railways'
[3.13.] Railway Network Statement	The Railway Network Statement is updated annually.
<b>[4.] Documents of the Lithuanian Republic</b>	
[4.1.] 'Instructions on Routine Railway Track Maintenance K/111'	Instructions on Routine Railway Track Maintenance K/111
[4.2.] 'Instructions on Maintenance of Man-made Structures 147/K'	'Instructions on Maintenance of Man-made Structures 147/K', approved under Order No 432 of the general director of the Lithuanian Railway (LG) dated 31.10.2001
[4.3.] 'Instructions on the Interpretation of Rail Spotter Readings and Track Evaluation, K/080'	Instructions on the Interpretation of Rail Spotter Readings and Track Evaluation, K/080, 1997
[4.4.] LST 1005384.0001 '1 520 mm Railways With Passenger Train Speeds of Up to 160 km per Hour (hr)'	Lithuanian Enterprise Standards LST 1005384.0001 1 520 mm Railways with Passenger Train Speeds of Up to 160 km/h
[4.5.] LST 1005384.0002 'Track Structure of 1 520 mm Gauge Railways with Passenger Train Speeds of Up to 160 km/h'	LST 1005384.0002 Track Structure of 1 520 mm Gauge Railways with Passenger Train Speeds of Up to 160 km/h
[4.6.] 'Railway Station Design Rules, 15/LG'	Railway Station Design Rules, 15/LG

<b>[No] Short document title</b>	<b>Full document title and document availability</b>
[4.7.] 'Lithuanian Railway PTE'	'Lithuanian Railway Standard Operating Procedures ADV/001, Approved by Order No 297 of the Minister of Railways of the Lithuanian Republic dated 20.09.1996 Lietuvos Respublikos susisiekimo ministro 1996 m. rugsėjo 20 d. įsakymas Nr. 297 „Dėl techninio geležinkelių naudojimo nuostatų patvirtinimo“
[4.8.] 'Rail Traffic Rules', ADV/003	Rail Traffic Rules, ADV/003
[4.9.] 'Rules on the Technological Design of Railway Signalling Devices', 25/AA	'Rules on the Technological Design of Railway Signalling Devices', 25/AA, Approved Under Order No I-185 dated 24.03.2003
[4.10.] 'Instructions on Earthing Power Supply Devices On Electrified Railways'	'Instructions on Earthing Power Supply Devices On Electrified Railways' 51/ AELG, Approved Under Order No I-366 dated 12.08.2005
[4.11.] STR 2.03.01.2001, 'Facilities and Grounds. Requirements Regarding Persons With Reduced Mobility'	Construction Technical Regulations STR 2.03.01.2001, 'Facilities and Grounds. Requirements Regarding Persons With Reduced Mobility'
[4.12.] 'Instructions on the Use of Structure Gauges'	Instructions on the Use of Structure Gauges (Railway Facility Level Requirements), No TsP-4425 dated 1986
[4.13.] LST EN 590:2004, Diesel Fuel	LST EN 590:2004, Diesel Fuel
[4.14.] LST EN 13262, Standardisation Document SD13	LST EN 13262 Standardisation Document SD13 (This document governs switch production and the requirements for new switches)
[4.15.] D1-232 'Rules on the Installation of Electrical Equipment for Specialised Premises and Technological Processes'	Order 4-140/D1-232 of the Minister of Business and the Minister of Environmental Protection of the Lithuanian Republic, 'Rules on the Installation of Electrical Equipment for Specialised Premises and Technological Processes'
[4.16.] 'Instructions on Railway and Highway Roadbed Design' SN 449-72	'Instructions on Railway and Highway Roadbed Design' SN 449-72. This Lithuanian language publication was confirmed by order of the chief executive officer of the LG dated 17 July 2006

<b>[No] Short document title</b>	<b>Full document title and document availability</b>
[4.17.] HN:2003 'Potable Water Safety and Quality Requirements'	Hygiene Standard HN:2003 'Potable Water Safety and Quality Requirements'
[4.18.] Railway Transportation Code of the Lithuanian Republic	Railway Transportation Code of the Lithuanian Republic, No IX-2152 dated 22.04.2004, with amendments document No X-653 dated 08.06.2006
<b>[5.] Documents of the Republic of Poland</b>	
[5.1.] Directive of the Minister of Transportation and the Maritime Economy dated 10.09.1998	Directive of the Minister of Transportation and the Maritime Economy dated 10.09.1998 (Legislative Journal, No 151, item 987)
[5.2.] Specifications for the Manufacture and Acceptance of Railway Rails, No ILK3d-518/03/07 dated 01.01.2008	Specifications for the Manufacture and Acceptance of Railway Rails, No ILK3d-518/03/07 dated 01.01.2008
[5.3.] Directive of the Minister of the Infrastructure dated 18.07.2005 on general conditions for traffic management and signalling, with subsequent amendments	Directive of the Minister of the Infrastructure dated 18.07.2005 on general conditions for traffic management and signalling, with subsequent amendments (Legislative Gazette No 172, article 1444)
[5.4.] Directive of the Minister of the Environment dated 14 June 2007 on permissible noise levels in the environment	Directive of the Minister of the Environment dated 14 June 2007 on permissible noise levels in the environment (Legislative Gazette, No 120, 2007, article 826)
[5.5.] Directive of the Minister of the Environment dated 2 October 2007 on requirements regarding the performance of substance or power level measurements in the environment by a highway, railway line, trolley line, airport, or port manager	Directive of the Minister of the Environment dated 2 October 2007 on requirements regarding the performance of substance or power level measurements in the environment by a highway, railway line, trolley line, airport, or port manager (Legislative Gazette, No 192, 2007, article 1392)
[5.6.] Directive of the Minister of the Economy dated 17 September 1999 on labour safety and hygiene for electric power equipment and wiring	Directive of the Minister of the Economy dated 17 September 1999 on labour safety and hygiene for electric power equipment and wiring (Legislative Gazette, No 80, 1999, section 55, article 912)

<b>[No] Short document title</b>	<b>Full document title and document availability</b>
[5.7.] 'Instructions on Work Place Safety and Hygiene for Railway Electric Power Equipment. Work on or near Catenary Equipment or Power Lines, Excluding the Traction Demands on EBH-1a Overhead Conductor Structures'	'Instructions on Work Place Safety and Hygiene for Railway Electric Power Equipment. Work on or near Catenary Equipment or Power Lines, Excluding the Traction Demands on EBH-1a Overhead Conductor Structures'
[5.8.] Id-4 (D-6) 'Instructions on Switch Service Inspections and Maintenance'	Id-4 (D-6) 'Instructions on Switch Service Inspections and Maintenance'
[5.9.] Id 19 Specifications for Superstructure Maintenance on 1 520 and 1 524-mm Gauge Railway Lines	Id 19 Specifications for Superstructure Maintenance on 1 520 and 1 524-mm Gauge Railway Lines
[5.10.] PN-EN 50122-1:2002 Railway Applications. Permanent Installations. Part 1: Protection Equipment Relating to Safety and Earthing	PN-EN 50122-1:2002 Railway Applications. Permanent Installations. Part 1: Protection Equipment Relating to Safety and Earthing
[5.11.] PN 85/B-02170 – Assessment of the Harmfulness of Vibrations Transmitted to Buildings by the Roadbed	PN 85/B-02170 – Assessment of the Harmfulness of Vibrations Transmitted to Buildings by the Roadbed
[5.12.] PN-S-10030:1985 Bridge Facilities – Loads	PN-S-10030:1985 Bridge Facilities – Loads
[5.13.] PN-EN 13481-2:2004 Method for Inspecting Stabilisation Systems	PN-EN 13481-2:2004 Method for Inspecting Stabilisation Systems
[5.14.] Technical Regulations for Railway Infrastructure Managers	Technical Regulations for Railway Infrastructure Managers
[5.15.] EN 590:2004 'Automatic Refuelling. Diesel. Requirements and Test Methods'	EN 590:2004 'Automatic Refuelling. Diesel. Requirements and Test Methods' SS-EN 590:2004 Automotive Fuels – Diesel – Requirements and Test Methods
[5.16.] Instructions on Railway Infrastructure Managers	Instructions on Railway Infrastructure Managers
<b>[6.] Documents of the Russian Federation</b>	
[6.1.] PTE for Railways of the Russian Federation	Standard Operating Procedures for the Railways of the Russian Federation dated 26 May 2000, Department of Traffic Safety document No TsRB-756

<b>[No] Short document title</b>	<b>Full document title and document availability</b>
[6.2.] Instructions on the Maintenance and Operation of Facilities, Devices, and Rolling Stock, and Traffic Management on High-Speed Passenger Train Interchange Segments, No TsRB-393	Instructions on the Maintenance and Operation of Facilities, Devices, and Rolling Stock, and Traffic Management on High-Speed Passenger Train Interchange Segments, No TsRB-393 dated 19 July 1996
[6.3.] STN Ts-01-95 '1 520 mm Gauge Railways'	Technical Construction Standards '1 520 mm Gauge Railways', STN Ts-01-95, approved by Order No 14Ts of the Railways Ministry of the Russian Federation (RF) on 25 September 1995
[6.4.] Instructions on the Routine Maintenance of Railway Tracks, TsP-774	Instructions on the Routine Maintenance of Railway Tracks, TsP-774 dated 1 July 2000
[6.5.] Order No 41 of the Railways Ministry dated 12.11.2001 'Standard Speed Limits for Rolling Stock on the 1 520 (1 524)-mm Gauge Railway Tracks of Federal Railway Transportation'	Order No 41 of the Railways Ministry dated 12.11.2001 and entitled 'Standard Speed Limits for Rolling Stock on the 1 520 (1 524)-mm Gauge Railway Tracks of Federal Railway Transportation'
[6.6.] Instructions No L-1318u of the Railways Ministry of Russia dated 18 November 1998	Instructions No L-1318u of the Railways Ministry of Russia dated 18 November 1998
[6.7.] Specifications for Track Repair Work and Scheduled Preventive Alignment, document No TsPT-53	Specifications for Track Repair Work and Scheduled Preventive Alignment, Department of Tracks and Facilities Engineering Division document No TsPT-53 dated 30 September 2003
[6.8.] Signal Boxes (STsB). Maintenance. Technological Design Standards (NTP) STsB/MPS-99	Signal Boxes. Maintenance. NTP STsB/MPS-99
[6.9.] Instructions on the Maintenance of Signal Boxes, No TsSh-720 dated 20.12.1999	Instructions on the Maintenance of Signal Boxes, No TsSh-720 dated 20.12.1999
[6.10.] Instructions on Application of Structure Gauges, TsP-4425, see [1.17.]	Instructions on Application of Structure Gauges, TsP-4425
[6.11.] Car-Washing Facility for Passenger Trains. Design Specifications. 2006	Car-Washing Facility for Passenger Trains. Design Specifications. 2006

<b>[No] Short document title</b>	<b>Full document title and document availability</b>
[6.12.] Standard Technological Process for Preparing and Servicing Passenger Trains en Route. 1880.01202.00029 (TK-140)	Standard Technological Process for Preparing and Servicing Passenger Trains en Route. 1880.01202.00029 (TK-140)
[6.13.] Instructions on the Maintenance of Manmade Structures. No TsP-628 dated 28 December 1998	Instructions on the Maintenance of Manmade Structures. No TsP-628 dated 28 December 1998
[6.14.] Instructions on the Earthing of Power Supply Devices on Electrified Railways, No TsE-191	Instructions on the Earthing of Power Supply Devices on Electrified Railways, No TsE-191 dated 10 June 1993
[6.15.] Instructions of the Railways Ministry of Russia dated 31.03.2000 'Technical Instructions on the Installation, Laying, Maintenance, and Repair of a Continuous-Welded Track'	Instructions of the Railways Ministry of Russia dated 31.03.2000 'Technical Instructions on the Installation, Laying, Maintenance, and Repair of a Continuous-Welded Track' (to be used for information purposes by an infrastructure manager)
[6.16.] Order No 41 of the MPS dated 12.11.2001	Order No 41 of the MPS dated 12.11.2001, see [6.5.]
[6.17.] ST.1.15.11.04-07 Public Health and Disease Control Safety Standard	ST.1.15.11.04-07 Public Health and Disease Control Safety Standard
[6.18.] Technical Regulations (TR) for Outfitting Railway Terminals	Technical Regulations for Outfitting Railway Terminals. Order of the MPS of the RF dated 1.11.1999
[6.19.] Long-Distance Passenger Railway Terminal Design Standards	Long-Distance Passenger Railway Terminal Design Process Industry Standards, 1998
<b>[7.] Documents of the Slovak Republic</b>	
[7.1.] Slovakian Railway PTE	Standard Operating procedures for Railways (P1), No 26221/1976 dated 01.01.1978 (hereinafter the Slovakian Railway PTE)
[7.2.] Regulations on the Slovakian Railway PTE	Regulations of the Federal Ministry of Transportation on the Standard Operating procedures for Railways, No 25188/1976 (hereinafter Regulations on the Slovakian Railway PTE)
[7.3.] Regulations of the Slovak Republic on Noise and Vibration Protection	Regulations No 40/2002 Coll. of the Government of the Slovak Republic on Health Protection Against Exposure to Noise and Vibrations (hereinafter the Regulations of the Slovak Republic on Noise and Vibration Protection)

<b>[No] Short document title</b>	<b>Full document title and document availability</b>
[7.4.] STN 280315 – 'Structure Gauge for 1 435-mm Gauge Track'	STN 280315 – Prechodové prierezy pre trate s rozchodom 1 435 mm 'Structure Gauge for a 1 435-mm Gauge Track')
[7.5.] STN P ENV 13803-1 Železnice. Parametre návrhu usporiadania koľaje. Rozchod 1 435 mm a širší. Časť 1: Koľaj (2004) (ENV 13803-1 Railway Applications. Track Alignment Design Parameters. Track Gauges of 1 435 mm and Wider. Plain Line)	STN P ENV 13803-1 Železnice. Parametre návrhu usporiadania koľaje. Rozchod 1 435 mm a širší. Časť 1: Koľaj (2004) (ENV 13803-1 Railway Applications. Track Alignment Design Parameters. Track Gauges of 1 435 mm and Wider. Plain Line) (hereinafter STN ZNV 13803-1)
[7.6.] TNZ 34 2605, 'Painting the Safety Designation Signs of Railway Signalling and Safety Devices'	TNZ 34 2605, Návestné nátery a bezpečnostné oznámenia na železničných oznamovacích a zabezpečovacích zariadeniach, Jún 2006, 01.08.2006 ('Painting the Safety Designation Signs of Railway Signalling and Safety Devices') (hereinafter TNZ 34 2605, Signalling and Safety Devices)
<b>[8.] Documents of the Ukraine</b>	
[8.1.] Ukrainian Railway PTE	Ukrainian Railway Standard Operating procedures Approved by order of the Ministry of Transport of Ukraine, No 411, of 20 December 1996.
[8.2.] TsP-0138 Instructions on the Installation and Maintenance of Ukrainian Railway Tracks	TsP-0138, Instructions on the Installation and Maintenance of Ukrainian Railway Tracks
[8.3.] DSTU 4344:2004 Standard Rails for Broad-Gauge Railways. General Specifications	State Standardisation System of the Ukraine DSTU 4344:2004 Standard Rails for Broad-Gauge Railways. General Specifications
[8.4.] SK DBN V.2.3 -14:2006 Bridges and Tubes	State Construction Standards for Structural Elements SK DBN V.2.3 -14:2006, Bridges and Tubes
[8.5.] 'DSTU 3868-99. Diesel Fuel. Specifications'	'DSTU 3868-99. Diesel Fuel. Specifications' «ДСТУ 3868-99. Паливо дизельне. Технічні умови»
[8.6.] DBN V.2.3.-19:2008	DBN V.2.3.-19:2008, Державні будівельні норми «Залізниця колії 1 520 mm»

<b>[No] Short document title</b>	<b>Full document title and document availability</b>
[8.7.] TsP-0020 Technical Instructions on Assessment of Track Geometry Based on Rail Spotter Readings and Ensuring Train Traffic Safety upon Deviation from Track Geometry Standards	TsP-0020 Technical Instructions on Assessment of Track Geometry Based on Rail Spotter Readings and Ensuring Train Traffic Safety upon Deviation from Track Geometry Standards
[8.8.] DNAOP 1.1.10-1.07-01. ISBN 966-7097-40-4	DNAOP 1.1.10-1.07-01. ISBN 966-7097-40-4, 'State Regulatory Acts on Occupational Safety and Health'
[8.9.] TsP-0117, Rules for Calculating Railway Track Strength and Stability	TsP-0117, Rules for Calculating Railway Track Strength and Stability
[8.10.] TsShEOT-0012 Instructions on the technical servicing of signal boxes	TsShEOT-0012 Instructions on technical servicing of signal boxes ЦШЕОТ 0012 Інструкція з технічного обслуговування пристроїв сигналізації, централізації та блокування (СЦБ)
[8.11.] Technological Design Rules for Automation and Telemechanical Devices on Ukrainian Railways, No 105-Ts of 17.04.2003.	Technological Design Rules for Automation and Telemechanical Devices on Ukrainian Railways, No 105-Ts of 17.04.2003.
[8.12.] Railway connections and intersections, general specifications SOU 45.080-00034045-002:2007	Railway connections and intersections, general specifications SOU 45.080-00034045-002:2007
[8.13.] Rules for calculation and design of 1 520 mm gauge rail cars	Rules for calculation and design of 1 520 mm gauge rail cars
[8.14.] SNiP II-39-76 Construction Rules and Regulations	SNiP II-39-76 Construction Rules and Regulations
[8.15.] TU No TsT-0034 'Sand for Locomotive Sanding Gear. Specifications'	TU No TsT-0034 'Sand for Locomotive Sanding Gear. Specifications', approved by order of Ukrainian Railways, dated 24.01.2002
[8.16.] Rules on Operation of Electrical Devices	Rules on Operation of Electrical Devices
<b>[9.] Estonian Documents</b>	
[9.1.] Directive of the Minister of Transport and Communications No 39 of 09.07.1999	Directive of the Minister of Transport and Communications No. 39 of 09.07.1999, determining only general use railway lines
[9.2.] RTL 1999, 127, 1773	RTL 1999, 127, 1773
[9.3.] RTL 2001, 129, 1870 Instructions on the application of construction gauges.	RTL 2001, 129, 1870 Instructions on the application of construction gauges.



<b>[No] Short document title</b>	<b>Full document title and document availability</b>
[9.4.] RTL 2001 129, 1870 Manual for the Application of Gauges	RTL 2001 129, 1870 Manual for the Application of Gauges
[9.5.] Estonian Railways PTE	Standard Operating procedures of Estonian Railways, approved by [9.1.] Directive of the Minister of Transport and Communications No 39 of 09.07.1999
[9.6.] EVS 867:2003/A1:2007, gauges	EVS 867:2003/A1:2007, gauges
[9.7.] EVS 2007 for Bridges and Tubes	EVS 2007 for Bridges and Tubes
[9.8.] EVS 867:2003/2006 standard	EVS 867:2003/2006 standard
[9.9.] 1985 Estonenergo Rules on Construction of Electrical Facilities	1985 Estonenergo Rules on Construction of Electrical Facilities
[9.10.] Rules on Construction of Contact Systems and Electrified Line Substations 9-1/23 30.09.2002 EVR	Rules on Construction of Contact Systems and Electrified Line Substations 9-1/23 30.09.2002 EVR
[9.11.] PPPV 1996	Rules for the use of passenger cars in interstate travel (PPPV) 1996
[9.12.] Instructions on Preparation of Freight Cars for Carriage	Instructions on Preparation of Freight Cars for Carriage
[9.13.] V-010 1998 EVR	V-010 1998 EVR
[9.14.] Railway Track Technical Maintenance Instructions	Railway Track Technical Maintenance Instructions

### 3 DEFINITIONS AND ABBREVIATIONS

<b>Abbreviation</b>	<b>Definition</b>
VNTP	Industry Technological Design Standards
BPC	Boundary Permissible Concentrations
GOST	State Standard
DSTU	State Standardisation System of Ukraine
CM	Cabinet of Ministers
LRW	Latvian Railway
MPS	Ministry of Railways
NTP	Technological Design Standards
PTE	Standard Operating procedures
SK DBN	State Construction Standards for Structural Elements
SN	Construction Standards
SNB	Construction Standards of Belarus
SNiP	Construction Codes and Regulations
STN	Construction Requirements and Standards
STP	Enterprise Standard
SRCI	Signalling, Routing Control, and Interlocking
TSI	Technical Specification for Interoperability
IM	Infrastructure Manager
CRI	Central Research Institute
TsP	Department of Tracks and Facilities (of the RF) or Central Administration for Track Facilities (of the Ukraine)
TsPT	Department of Tracks and Facilities Engineering Division (of the RF)
TsRB	Department of Traffic Safety (of the RF) or Central Administration for Traffic Safety and Ecology (of the Ukraine)
CCRT	Central Council on Railway Transportation of the Member Nations of the Commonwealth, the Republic of Latvia, the Republic of Lithuania, and the Republic of Estonia
ADV	Rail Traffic Rules
EN	European Standard
LST	Lithuanian Enterprise Standard
LHS	Limited Liability Company (LLC) Broad-Gauge Metallurgical Railway Line

LG	Lithuanian Railway
LVS	Latvian State Standard
PN	Polish Standard
STR	Construction Technical Regulations (Lithuania)
HN	Hygiene Standard (Lithuania)

<b>Term</b>	<b>Definition</b>
Minimum structure gauge	The distance on an axis perpendicular to the rails within which there should be no parts of any structure, building or device. The sole exception is devices intended for direct contact with rolling stock: contact systems and fixtures, car brakes, swinging hydraulic arms for water replenishment, etc.
Distance between track centres	The distance between two railway tracks
Ruling (baseline) gradient	A gradient of undefined length that a single locomotive can pull a train of a specified mass over at a given speed
Limiting gradient	The maximum gradient for profile elevation elements
Horizontal curve	A section of track deviating from a straight line horizontally
Vertical curve	A section of track deviating from a straight line vertically
Marshalling line	A siding intended and equipped for receiving and dispatching trains.
Track gauge	The distance between the inner sides of rails, measured 13 mm below the rail head
Cant	Elevation of one rail above the other to reduce track load from centrifugal force on the rolling stock.

Term	Definition
Cant deficiency	<p>In curves, cant deficiency is the difference, expressed in mm, between the applied cant on the track and the equilibrium cant for the vehicle at the particular stated speed.</p> <p>(Definition taken from TSI Infrastructure sub-system, p.4.2.8. For example, in Latvia this parameter is applied on the basis that up to 115 mm cant deficiency compared to equilibrium is permitted for passenger trains travelling at a greater speed than freight trains. Equilibrium cant is cant sufficient to ensure that a train travelling at a particular speed through a particular curve will rest on each rail equally, and the cant will absorb the centrifugal force).</p>
Rate of change of cant	<p>A change in cant over a unit of length of curvature, expressed as mm/m.</p> <p>Full ramping (from zero to maximum cant) usually takes place without a transition curve, on the straight.</p>
Rail profile	The shape of the rail cross section
Equivalent conicity	Equivalent conicity is the tangent of the cone angle of a wheelset with coned wheels whose lateral movement has the same kinematic wavelength as the given wheelset on straight track and large-radius curves. (definition taken from TSI Infrastructure subsystem, p.4.2.9.)
Rail inclination	The angle at which the rails are fixed inclining inwards to compensate for the action of rolling stock wheel sets pushing the rails outwards.
Track stiffness	<p>The ability of the track to resist force applied to the track by changing its geometric parameters.</p> <p>Vertical track rigidity – the relationship between vertical force applied to the centre of the railhead and vertical track deflection at the load point.</p>
Electric insulation of track	Separation of conductive elements (rail, metal parts, other track elements) by a dielectric to prevent direct electrical contact or discharges between them
Means of locking	Device ensuring (mechanical) or controlling (electrical) the proper alignment of the switch of a crossing with the guard rail

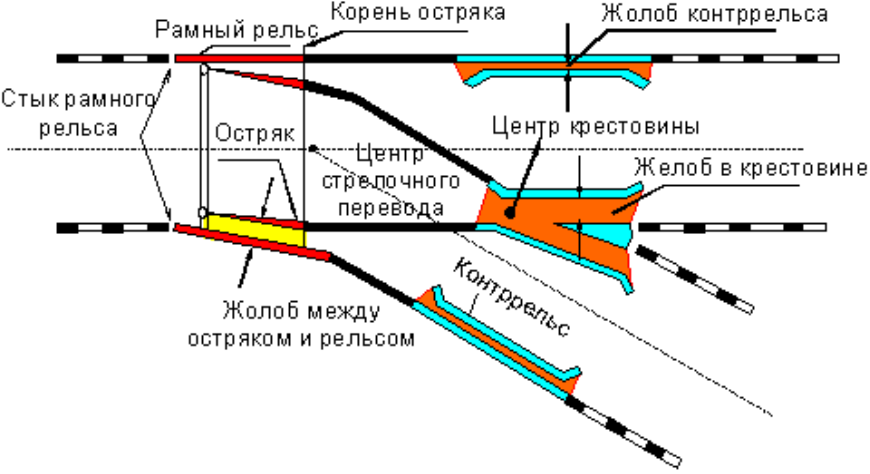
Term	Definition
Switch	Part of a turnout consisting of running rails, blades, and a switch box. Where there is a swingnose frog, the frog falls within the scope of switch.
Turnout	<p>A device enabling rolling stock to cross from one track to another. Turnouts consist of switches, frogs, and connecting track. Frogs may be fixed or swingnose.</p>  <p>[Key, clockwise from left: running rail joint; running rail; pin of switches; check rail flangeway; frog center (intersection); frog flangeway; check rail; center of turnout; flangeway between blades and rail; blade.]</p>
Girder-type rail crossing	A crossing on one level, without the train being able to cross from one track to another
Maximum unguided length of fixed obtuse crossings	A gap in the frog crossed during a switch where the wheel flange is not guided by a rail (a check rail is used to prevent derailing by guiding the second wheel of the wheelset).
Passenger platform	A railway infrastructural element within a station or at a stopping point intended to allow safe and convenient boarding and disembarking, as well as a place to wait for trains.
People with reduced mobility	Persons that may experience difficulty using trains and related infrastructure. (The PRM TSI contains several categories)
Piston effect	<p>Means of tunnel ventilation.</p> <p>A train entering a tunnel pushes air in front and sucks air from behind into the tunnel.</p>

<b>Term</b>	<b>Definition</b>
Traffic density	A parameter describing the level of use of a rail network, expressed as t/km, per 1 km of operating length of the railway, or tons of freight passing through a point on the rail network within a specified period
Block	Section of railway line between neighbouring stations, sidings, marshalling yards, or block posts.
Mainline	Blocks or station lines that are a direct extension of adjoining blocks and, as a rule, do not diverge at switches.
Station	A point on the line capable of accepting, dispatching, combining, and shunting trains, servicing passengers, and where track facilities allow, marshalling to break up and form trains and perform technical operations with trains.
General line	A railway line equally accessible for freight and passenger trains, or for supporting other technological processes
Access spur Industrial spur line	A line intended to serve individual enterprises, organisations, institutions (factories, plants, mines, forestry works, power stations, traction substations, etc.), connected to the general rail network by an uninterrupted line and owned by the railway, enterprise, organisation, or institution.
Servicing yard	A part of railway infrastructure where materials (fuel, lubricants, water, sand) are replenished.
Freight hauling direction	Direction of main freight flows

#### 4 LIST OF BASIC PARAMETERS

This list sets forth the parameters determining the technical and operational compatibility of the subsystem 'Infrastructure. Permanent Way and Track Facilities' for 1 520 mm railway systems at the CIS-EU border. This list was produced on the basis of the Infrastructure TSI currently under development, adapted and expanded with consideration for the features of 1 520 mm gauge railways.

	<b>Russian name</b>	<b>English name (according to the Infrastructure TSI draft)</b>
<b>1.</b>	<b>Параметры трассы</b>	<b><i>Line layout</i></b>
1.1.	Габарит приближения строений	<i>Minimum structure gauge (4.2.4.1)</i>
1.2.	Ширина междупутья	<i>Distance between track centres (4.2.4.2)</i>
1.3.	Предельные значения уклона при подъёме и спуске	<i>Maximum gradients (4.2.4.3)</i>
1.4.	Наименьший допустимый радиус горизонтальной кривой	<i>Minimum radius of horizontal curve (4.2.4.4)</i>
1.5.	Наименьший допустимый радиус вертикальной кривой	<i>Minimum radius of vertical curve (4.2.4.5)</i>
1.6.	Длина приемоотправочных путей	<i>Length of station entry and departure tracks</i>
<b>2.</b>	<b>Параметры верхнего строения пути</b>	<b><i>Track parameters</i></b>
2.1.	Ширина колеи	<i>Nominal track gauge (4.2.5.1)</i>
2.2.	Возвышение наружного рельса	<i>Cant (4.2.5.2)</i>
2.3.	Величина допускаемого максимального недовозвышения наружного рельса	<i>Cant deficiency (4.2.5.4)</i>
2.4.	Отвод возвышения наружного рельса (постепенное снижение повышенной наружной нити до нуля)	<i>Rate of change of cant (4.2.5.3)</i>
2.5.	Профиль рельса (вне стрелочных переводов и пересечений путей)	<i>Railhead profile for plain line (4.2.5.6)</i>
2.6.	Эквивалентная конусность (геометрия взаимодействия системы «колесо-рельс»)	<i>Equivalent conicity (4.2.5.5)</i>
2.7.	Подуклонка рельса	<i>Rail inclination (4.2.5.7)</i>
2.8.	Жёсткость пути	<i>Track stiffness (4.2.5.8)</i>
2.9.	Электрическая изоляция пути	<i>Electric insulation of rails (4.2.5.9)</i>

	<b>Russian name</b>	<b>English name (according to the Infrastructure TSI draft)</b>
<b>3.</b>	<b>Требования к стрелочным переводам и пересечениям путей</b>	<b><i>Switches and crossings</i></b>
3.1.	Средства замыкания	<i>Means of locking (4.2.6.1)</i>
3.2.	Геометрические характеристики стрелочных переводов и пересечений путей	<i>In service geometry of switches and crossings (4.2.6.2)</i>
3.3.	Предельные значения длины вредного пространства (участка стрелочного перевода или пересечения путей, при прохождении через который гребень колеса не направляется рабочей гранью)	<i>Maximum unguided length of fixed obtuse crossings (4.2.6.3)</i>
<b>4.</b>	<b>Механическая прочность пути</b>	<b><i>Track resistance to applied loads</i></b>
4.1.	Вертикальные нагрузки	<i>Track resistance to vertical loads (4.2.7.1)</i>
4.2.	Продольные нагрузки	<i>Longitudinal track resistance (4.2.7.2)</i>
4.3.	Поперечные нагрузки	<i>Lateral track resistance (4.2.7.3)</i>
<b>5.</b>	<b>Нагрузка при движении по искусственным сооружениям</b>	<b><i>Structures resistance to traffic loads</i></b>
5.1.	Нагрузки на мосты	<i>Resistance of bridges to traffic loads (4.2.8.1)</i>
5.2.	Нагрузки на земляные сооружения	<i>Equivalent vertical loading for earthworks and earth pressure effects (4.2.8.2)</i>
5.3.	Нагрузка на искусственные сооружения, расположенные над путём или вблизи пути	<i>Resistance of structures over or adjacent to tracks (4.2.8.3)</i>
<b>6.</b>	<b>Качество положения (геометрического состояния) пути и допуски дефектов на отдельных участках пути</b>	<b><i>Track geometrical quality and limits on isolated defects</i></b>
6.1.	Определение предельных значений (допуска) для «незамедлительного действия», «действия» и «повышения бдительности»	<i>Determination of immediate action, intervention, and alert limits (4.2.9.1)</i>
6.2.	Предельные значения (допуска) для «незамедлительного действия» при искривлении пути	<i>The immediate action limit for track twist (4.2.9.2)</i>



	<b>Russian name</b>	<b>English name (according to the Infrastructure TSI draft)</b>
6.3.	Предельные значения (допуска) для «незамедлительного действия» при изменении ширины колеи	<i>The immediate action limit for variation of track gauge (4.2.9.3)</i>
6.4.	Предельные значения (допуска) для «незамедлительного действия» при изменении возвышения наружного рельса	<i>The immediate action limit for cant (4.2.9.4)</i>
<b>7.</b>	<b>Требования к платформам</b>	<b><i>Platforms</i></b>
7.1.	Длина платформы	<i>Usable length of platforms (4.2.10.1)</i>
7.2.	Ширина платформы	<i>Width and edge of platforms (4.2.10.2)</i>
7.3.	Высота платформы (высокая и низкая)	<i>Height of platforms (4.2.10.4)</i>
7.4.	Расстояние между краем платформы и осью пути	<i>Offset of platforms (4.2.10.5)</i>
7.5.	Доступность для лиц с ограниченной подвижностью	<i>Characteristics of platforms linked to the access of people with reduced mobility (4.2.10.6)</i>
7.6.	Нанесение разметки безопасности на платформе (край и конец)	<i>Width and edge of platforms (4.2.10.2)</i> <i>End of platforms (4.2.10.3)</i>
<b>8.</b>	<b>Требования, связанные с защитой здоровья, безопасностью и защитой окружающей среды</b>	<b><i>Health, safety and environment</i></b>
8.1.	Предельные значения изменения давления в туннелях	<i>Maximum pressure variation in tunnels (4.2.11.1)</i>
8.2.	Поршневой эффект на подземных станциях	<i>Piston effects in underground stations (4.2.11.2)</i>
8.3.	Требования по уровню шума и вибрации	<i>Noise and vibration limits and mitigation measures (4.2.11.3)</i>
8.4.	Противошоковая электрическая защита	<i>Protection against electric shock (4.2.11.4)</i>
8.5.	Безопасность в железнодорожных туннелях	<i>Safety in railway tunnels (4.2.11.5)</i>
8.6.	Поперечная ветровая нагрузка	<i>Effect of crosswinds (4.2.11.6)</i>
<b>9.</b>	<b>Требования, связанные с эксплуатацией</b>	<b><i>Provision for operation</i></b>
9.1.	Требования к маркировке пути	<i>Distance markers (4.2.12.1)</i>

	<b>Russian name</b>	<b>English name (according to the Infrastructure TSI draft)</b>
<b>10.</b>	<b>Требования к стационарным установкам, предназначенным для обслуживания поездов</b>	<i>Fixed installations for servicing trains</i>
10.1.	Оборудование для слива туалета	<i>Toilet discharge (4.2.13.1)</i>
10.2.	Оборудование для мойки поездов	<i>Train external cleaning facilities (4.2.13.2)</i>
10.3.	Оборудование для заправки водой	<i>Water restocking (4.2.13.3)</i>
10.4.	Оборудование для заправки песком	<i>Sand restocking (4.2.13.4)</i>
10.5.	Оборудование для заправки топливом	<i>Refuelling (4.2.13.5)</i>
10.6.	Оборудование для электропитания поездов на стоянке	<i>Electric shore supply (4.2.13.6)</i>

In the list above, parameter 1.6 is a basic parameter in the Conventional Rail Infrastructure TSI basic parameters; it has been added to the list by the groupe that prepared this document. Parameters 2.9, 7.5, 8.2 and 10.4 were in the draft list of basic parameters of the Conventional Rail Infrastructure TSI at the time when the groupe that prepared this document started its work; these parameters however have not been included in the final version of the TSI.

## 5 ANALYSIS OF BASIC PARAMETERS

The thresholds for certain parameters are set depending on the line category. Lines are categorised differently from state to state, in each case depending on specific economic, geographic, operational, and other characteristics of the specific state. There is no separation of passenger and freight lines in 1 520 mm rail systems.

The following documents are used to categorise lines in 1 520 mm gauge railway systems:

Belarus	[6.3.] STN Ts-01-95, '1 520 mm Gauge Railways' [2.3.] SNB 3.03.01-98 '1 520 mm Railways'
Latvia	[3.11.] Cabinet of Ministers Regulations No 566 'Method for Categorisation of Railway Infrastructure of Strategic and Regional Significance' dated 29.06.2004 [1.1.] Construction Norms and Regulations (SNiP) II-39-76 '1 520 mm Gauge Railways' (used by the Infrastructure Manager for information purposes)
Lithuania	[4.18.] Railway Transportation Code of the Lithuanian Republic [1.6.] SNiP 32-01-95 '1 520 mm Gauge Railways' (information purposes only)
Poland	Directive of the Minister of Transportation and the Maritime Economy dated 10.09.1998 (Legislative Journal, No 151, item 987)
Russia	[6.3.] STN Ts-01-95 '1 520 mm Gauge Railways' [1.6.] SNiP 32-01-95 '1 520 mm Gauge Railways'
Slovakia	[7.2.] Regulations on the Slovakian Railway PTE [7.4.] STN 280315 – 'Structure Gauge for 1 435-mm Gauge Track'
Ukraine	[1.1.] Construction Norms and Regulations (SNiP) II-39-76 '1 520 mm Gauge Railways' (for information only)
Estonia	[9.5.] Standard Operating procedures of Estonian Railways, approved by [9.1.] Directive of the Minister of Transport and Communications No 39 of 09.07.1999, only for general purpose lines [1.6.] SNiP 32-01-95 '1 520 mm Gauge Railways' (used by the Infrastructure Manager for information purposes)

[6.3.] STN Ts-01-95 '1 520 mm Gauge Railways', [1.6.] SNiP 32-01-95 '1 520 mm Gauge Railways' and [2.3.] SNB 3.03.01-98 '1 520 mm Railways' (applicable in Belarus, Lithuania, Russia and Estonia) establish the following line categories:

Railway line category	Railway purpose	Baseline annual net traffic density after 10 years of operation, million tkm/km
Express	Mainline railways for passenger trains travelling at speeds of 160 km/h to 200 km/h	—
High traffic density	Railway mainlines for high volumes of freight traffic	More than 50
I	Mainline railways	30 to 50
II	Mainline railways	15 to 30
III	Mainline railways	8 to 15
IV	Railway lines	Up to 8
	Sidings	Regardless of traffic density

[1.1.] Construction Norms and Regulations (SNiP) II-39-76 '1 520 mm Gauge Railways' (used in Latvia and Ukraine for information purposes)<sup>1</sup> establishes the following line categories:

Railway line category	General economic purpose of railway	Baseline annual net annual traffic density, million tkm/km		Passenger train traffic after five years of operation, wheelsets per day	Maximum train speed, km/h
		After five years	After 10 years		
I	Mainline railways or parts thereof forming the main national transportation system domestically or connecting to other countries	More than 12	More than 20	More than 12, except suburban trains or more than 50 for local trains	More than 120 (for passenger trains)
II	Mainline railways (lines) or parts thereof primarily used for inter-regional freight and passenger transport domestically or into other countries	7 to 12	10 to 20	5-12, except local trains	-
III	Railway lines primarily used for local freight and passenger transportation	3-7	5-10	Not more than 4, except local trains	-
IV	Local railway lines where growth in traffic density is not expected until the tenth year of operations	Less than 3	less than 5	-	-
	Spurs unlikely to be included in the general network by the tenth year of	Regardless of traffic density		-	More than 40 for freight train haulage

<sup>1</sup> In Latvia and Ukraine, [1.1.] Construction Norms and Regulations (SNiP) II-39-76 '1 520 mm Gauge Railways' applies for information purposes, but the system of categories in this document is not used.

	operation			
V	Spurs and sidings at stations	Regardless of traffic density	-	40 or less for freight trains for haulage or manoeuvres

Latvian national law ([3.11.] Cabinet of Ministers Regulations No 566) establishes the following line categories:

Category	
I	Strategic sections with a traffic density of more than 15 million tons per year or passenger train speeds of 120 km/h or higher.
II	Strategic sections that are not in category I or regional sections <sup>2</sup> with a traffic density of 5 to 15 million tons per year, or passenger train speeds of 80-120 km/h, and sections used by local electric trains.
III	All other regional rail infrastructure.

The Lithuanian PTE establishes the following categories by speed:

Category	Speed, passenger/freight trains (km/h)
I	140/90
II	120/80
III	100/80
IV	80/70
V	50/40
VI	25/25

A new edition of the PTE is currently in preparation in Lithuania. This year, planning for modernisation work on the Vilnius–Kaunas line began, with passenger speeds to be raised to 160 km/h, requiring revisions to speed categories.

Slovakia has only 88.051 km of second category freight lines using the 1 520 mm gauge. Plans exist for new combined freight-passenger lines using the 1 520 mm gauge, which may be a higher category.

There is no difference in categories in Poland for 1 520 mm and 1 435 mm lines. The categories and operating parameters of the railways are given in the following table:

<sup>2</sup> Track status – regional or strategic – is determined by the Cabinet of Ministers.

	Railway lines by category	Traffic density T (million t/year)	Maximum speed V <sub>max</sub> (km/h)	Maximum speed, freight trains V <sub>t</sub> (km/h)	Permitted axle load P (kN)
<i>1</i>	<i>2</i>	<i>3</i>	<i>4</i>	<i>5</i>	<i>6</i>
1	Mainline (0)	$T \geq 25$	$120 < V_{max} \leq 200$	$80 < V_{max} \leq 120$	$P \leq 221$
2	First class (1)	$10 \leq T < 25$	$80 < V_{max} \leq 120$	$60 < V_{max} \leq 80$	$210 \leq P < 221$
3	Second class (2)	$3 \leq T < 10$	$60 < V_{max} \leq 80$	$50 < V_{max} \leq 60$	$200 \leq P < 210$
4	Local (3)	$T < 3$	$V_{max} \leq 60$	$V_{max} \leq 50$	$P < 200$

It is not possible to combine these varying categories into a unified system within the scope of this work.

If a unified system of classification were to be produced, a similar approach could be taken as in the Infrastructure TSI project (axle load, speed, length of train), with an additional section for 'traffic density'.

## 5.1 LINE LAYOUT

### 5.1.1 Minimum structure gauge

The requirements for this parameter are identical in all eight states.

The minimum structure gauge for railway buildings and devices, and railway spurs must meet the following requirements:

'Gauge S' (according to [1.12.] GOST 9238-83 '1 520 (1 524) mm Gauge Railway Minimum Gauges for Structures and Rolling Stock', section 2, fig. 1, 4, 5) for track, structures and devices of the general railway system and external spurs from the connecting station to the territory of industrial and transportation enterprises (fig. 1, 4, 5);

'Gauge Sp' (according to [1.12.] GOST 9238-83 '1 520 (1 524) mm Gauge Railway Minimum Gauges for Structures and Rolling Stock', section 2, fig. 2, 4-6) for track, structures and devices on the territory between the territory of factories, plants, workshops, marshalling yards, river and sea ports, mines, freight yards, bases, warehouses, quarries, forestry and peat works, power stations and other industrial and transportation enterprises, as well as industrial railway stations.

Method of conformity assessment: measurement of geometric dimensions.

These requirements are approved in the following documents:

Belarus	[1.12.] GOST 9238-83 '1 520 (1 524) mm Gauge Railway Minimum Gauges for Structures and Rolling Stock' section 2 [2.1.] PTE of the Belarusian Railway, section 2.4.
Latvia	[3.3.] 'PTE of the Latvian Railway' [3.2.] LVS 282-2005 'Structure and Loading Gauges' (conforms to [1.12.] GOST 9238-83 '1 520 (1 524) mm Gauge Railway Minimum Gauges for Structures and Rolling Stock') (PTE requires compliance with this standard)
Lithuania	[4.12.] 'Instructions on the Use of Structure Gauges' (conforms to [1.12.] GOST 9238-83 '1 520 (1 524) mm Gauge Railway Minimum Gauges for Structures and Rolling Stock')
Poland	[5.1.] Directive of the Minister of Transportation and the Maritime Economy dated 10.09.1998 (Legislative Journal No 151, p. 987, section 94). (This document cites [1.12.] GOST 9238-83 '1 520 (1 524) mm Gauge Railway Minimum Gauges for Structures and Rolling Stock').
Russia	[6.1.] PTE for Railways of the Russian Federation [1.12.] GOST 9238-83 '1 520 (1 524) mm Gauge Railway Minimum Gauges for Structures and Rolling Stock', [1.17.] Central Order (TsP)-4425 Instructions on Application of Minimum Structure Gauges
Slovakia	[7.2.] Regulations on the Slovakian Railway PTE [7.1.] Slovakian Railway PTE [7.4.] STN 280315 – 'Structure Gauge for 1 435-mm Gauge Track'
Ukraine	[1.12.] GOST 9238-83 '1 520 (1 524) mm Gauge Railway Minimum Gauges for Structures and Rolling Stock' Instructions on application of structure gauges. [8.1.] Ukrainian Railway PTE section 2.4.
Estonia	[9.1.] Directive of the Minister of Transport and Communications No 39 of 09.07.1999 (document cites [1.12.] GOST 9238-83 '1 520 (1 524) mm Gauge Railway Minimum Gauges for Structures and Rolling Stock') [9.3.] RTL 2001, 129, 1870 Instructions on the application of construction gauges.

## Comments:

[1.12.] GOST 9238-83 '1 520 (1 524) mm Gauge Railway Minimum Gauges for Structures and Rolling Stock' includes requirements for both Rolling Stock and Infrastructure.

OSJD Leaflets [1.38.] O-500, [1.39.] P-500/1 – [1.43.] P-500/5, [1.44.] O-501, [1.45.] P-501/1, [1.46.] O-502, establish loading gauges corresponding to [1.12.] GOST 9238-83

'1 520 (1 524) mm Gauge Railway Minimum Gauges for Structures and Rolling Stock'. These Leaflets apply in all eight states.

Conclusion: The requirements for this parameter are identical in all eight states. These requirements and documents may be taken as the basis for developing uniform requirements for 1 520 mm gauge system.

### 5.1.2 Distance between track centres

The requirements for this parameter are now identical in all eight states.

The permitted distance between track centres on straight sections and curved sections with a radius of more than 4 000 m must meet the following requirements:

<b>Line type</b>	<b>Distance between track centres</b>
Mainline route	4 100 mm
On the third and fourth lines, space between centres of second and third lines	5 000 mm
Between centres of neighbouring lines in stations, straight lines	4 800 mm
On secondary tracks and tracks in freight areas	4 500 mm
Between centres of lines used for transfer of freight from car to car	3 600 mm

Horizontal distances on curved sections between centres of neighbouring track and between the centre of the line and the minimum structure gauge on lines and in stations are adjusted (increased) depending on the curve radius and safe rolling stock passage.

Method of conformity assessment: measurement of geometric dimensions.

These requirements are approved in the following documents:

Belarus	[2.1.] PTE of the Belarusian Railway, section 2.5. [1.12.] GOST 9238-83 '1 520 (1 524) mm Gauge Railway Minimum Gauges for Structures and Rolling Stock' section 2.6. [2.2.] Enterprise Standards document (STP) 09150.56.010-2005 'Routine Railway Track Maintenance. Technical Requirements and Work Management' section 5.1.12.
---------	--



Latvia	[3.3.] 'PTE of the Latvian Railway' section 15, 16. [3.2.] LVS 282-2005 'Structure and Loading Gauges' (PTE requires compliance with this standard)
Lithuania	[4.1.] 'Instructions on Routine Railway Track Maintenance K/111' [4.7.] 'Lithuanian Railway '
Poland	[5.1.] Directive of the Minister of Transportation and the Maritime Economy dated 10.09.1998 (Legislative Journal No 151, p. 987, para. 94).
Russia	[6.1.] PTE for Railways of the Russian Federation
Slovakia	[7.2.] Regulations on the Slovakian Railway PTE [7.1.] Slovakian Railway PTE
Ukraine	[1.12.] GOST 9238-83 '1 520 (1 524) mm Gauge Railway Minimum Gauges for Structures and Rolling Stock', section 4. [8.2.] TsP-0138 Instructions on the Installation and Maintenance of Ukrainian Railway Tracks section 2.8, [8.1.] Ukrainian Railway PTE section 2.5
Estonia	[9.2.] RTL 1999, 127, 1773 [9.3.] RTL 2001, 129, 1870 Instructions on the application of construction gauges.

Conclusion: The requirements for this parameter are identical in all eight states. These requirements and documents may be taken as the basis for developing uniform requirements for 1 520 mm gauge system.

### 5.1.3 Maximum gradients

Requirements for this parameter vary between states at this time.

The maximum gradients are set depending on the line category. As stated in section 5, line categorisation varies between states, and in each case takes into consideration the specific economic, geographical, operational, and other conditions in that state.

The next table states the maximum gradients by line category and value of gradient limit in accordance with section 3.3 of [1.6.] SNiP 32-01-95 '1 520 mm Gauge Railways' (applicable in Russia, and as an information document in Lithuania and Estonia) and section 3.3 of [2.3.] SNB 3.03.01-98 '1 520 mm Railways' (applicable in Belarus), and the ruling gradient for freight lines in accordance with section 4.1 [6.3.] STN Ts-01-95 '1 520 mm Gauge Railways' (applicable in Belarus and Russia):

<b>Line category</b>	<b>Limiting gradient ([1.6.] SNiP 32-01-95 and [2.3.] SNB 3.03.01-98)</b>	<b>Ruling gradient, freight lines ([6.3.] STN TS-01-95)</b>
High traffic density	18‰	9‰
I	18‰	12‰
II	20‰	15‰
III	30‰	20‰
IV	40‰	30‰*

\* 40% is permitted in especially difficult conditions

In accordance with Chapter 39 of [8.14.] SNiP II-39-76 Construction Rules and Regulations (applicable as an information document in Ukraine), the ruling gradient shall not exceed, depending on line category, the following values:

<b>Line category</b>	<b>Ruling gradient ([8.14.] SNiP II-39-76)</b>
I	15‰*
II	15‰
III	20‰
IV	30‰
V	30‰

\* On new category I lines, where locomotive traction passenger trains speeds over 120 km/h are permitted, the ruling gradient shall not exceed 9‰, and 12‰ in difficult conditions.

Section 19 of SNiP II-39-76 governs requirements for gradients on in-station sections of track: 1.5 mm/m, in exceptional circumstances to 2.5 mm/m with car roll prevention.

New railways have not been built in Latvia in recent years, and no requirement for ruling or limiting gradients has been established. For existing lines the ruling gradient was determined in accordance with the design and construction rules applicable at the time they were built. SNiP II-39-76 may be used at present only as a guide.

Poland: ruling gradient values apply according to line category:

<b>Line category</b>	<b>Ruling gradient</b>
----------------------	------------------------

1. Main lines and first class lines	6‰
2. Second class lines	10‰
3. Local lines and spurs	20‰

When setting ruling gradients, the railway administration considers the operating conditions, train speeds, traction units' power, and energy consumption.

Slovakia: 17 mm/m.

Conformity assessment method: geometric measurement.

These requirements are approved in the following documents:

Belarus	[2.3.] SNB 3.03.01-98 '1 520 mm Railways', section 3.3
Latvia	[3.3.] 'PTE of the Latvian Railway'. [1.1.] Construction Norms and Regulations (SNiP) II-39-76 '1 520 mm Gauge Railways'. Design rules section 2.1. (Applicable for information purposes by the Infrastructure Manager)
Lithuania	[1.6.] SNiP 32-01-95 '1 520 mm Gauge Railways' (Applicable for information purposes only).
Poland	[5.1.] Directive of the Minister of Transportation and the Maritime Economy dated 10.09.1998 (Legislative Journal No 151, p. 987, section 37) These requirements apply to both 1 435 mm and 1 520 mm lines.
Russia	[1.6.] SNiP 32-01-95 '1 520 mm Gauge Railways', section 3.3 [6.3.] STN Ts-01-95 '1 520 mm Gauge Railways', section 4.1
Slovakia	[7.2.] Regulations on the Slovakian Railway PTE [7.1.] Slovakian Railway PTE
Ukraine	[8.14.] SNiP II-39-76 Construction Rules and Regulations, Part II Chapter 39.
Estonia	[9.5.] Estonian Railways PTE, chapter 2, paragraph 18, these SNiP must be taken into consideration.

Conclusion: These requirements vary across the states. A uniform system of line categorisation is required before developing uniform requirements for 1 520 mm gauge railways.

#### 5.1.4 Minimum radius of horizontal curve

The requirements for this parameter are identical in all states except Poland and Slovakia.

The minimum radius of horizontal curve is established depending on line category, rail category and design speed.

The following values are absolute minima:

Main, marshalling yard, and sorting lines:	300 m
Other general use station lines:	200 m (Belarus, Latvia, Lithuania, Russia, Ukraine, and Estonia) 180 m (Poland) 190 m (Slovakia)
Industrial spurs:	150 m

On all lines (other than main, marshalling yard, and sorting) used by organised trains, S-bends with a radius of 250 m or less must be separated by a straight insert of at least 15 m when curves are built without rail cant.

Conformity assessment method: geometric measurement.

These requirements are approved in the following documents:

Belarus	[2.2.] Enterprise Standards document (STP) 09150.56.010-2005 'Routine Railway Track Maintenance. Technical Requirements and Work Management', section 5.1.8, section 5.1.9.
Latvia	[3.4.] 'Instructions on Routine Track Maintenance', section 2.11
Lithuania	[4.1.] 'Instructions on Routine Railway Track Maintenance K/111'
Poland	[5.1.] Directive of the Minister of Transportation and the Maritime Economy dated 10.09.1998 (Legislative Journal No 151, p. 987, section 32)
Russia	[6.3.] STN Ts-01-95 '1 520 mm Gauge Railways'
Slovakia	[7.2.] Regulations on the Slovakian Railway PTE [7.1.] Slovakian Railway PTE [7.4.] STN 280315 – 'Structure Gauge for 1 435-mm Gauge Track'
Ukraine	[8.2.] TsP-0138 Instructions on the Installation and Maintenance of Ukrainian Railway Tracks, section 2.1.2

Estonia	[9.5.] Estonian Railways PTE, section 20 [1.6.] SNiP 32-01-95 '1 520 mm Gauge Railways'
---------	--

Conclusion: The requirements for this parameter are the same in all states, except Poland and Slovakia. These documents and requirements may be used as the basis for developing uniform specifications for 1 520 gauge systems (with consideration for the minor differences in Poland and Slovakia).

### 5.1.5 Minimum radius of vertical curve

This requirement varies across the states.

The minimum radius of vertical curve is set depending on line category, rail category and design speed.

In accordance with section 4.5 of [6.3.] STN Ts-01-95 '1 520 mm Gauge Railways' (applicable in Belarus and Russia, and for information purposes in Lithuania), neighbouring elements in elevation have the following vertical curve radii (km):

Category	According to design, construction and reconstruction standards	For design of additional mainlines or reconstruction in difficult conditions
Especially high traffic density	20	15
I	15	10
II	15	10
III	10	5
IV	5	3
Other	-	-

Vertical curves may be omitted where there are algebraic differences between neighbouring inclines of less than 2.3‰, where  $R_B=15$  km; 2.8‰ where  $R_B=10$  km; 4‰ where  $R_B=5$  km; 5.2‰ where  $R_B=3$  km.

Latvia: Neighbouring elements in elevation with an algebraic difference in inclines of more than 0.003 interconnect in the vertical plane with a curve radius of 10 000 m on category I and II lines, and 5 000 m on category III lines. For technical reasons, or on spur lines, interconnecting elements with a vertical curve radius of 2 000 m are permitted.

In accordance with [8.2.] TsP-0138 Instructions on the Installation and Maintenance of Ukrainian Railway Tracks, section 2.7.1, neighbouring elements in elevation interconnect in the vertical plane with curves of the following radii (km):

Category		In difficult conditions
I-III	15	10
IV-V	10	5
VI-VII	5	3
Station and spur lines	3	2

Poland: 2 000 m and 500 m by way of exception on ancillary lines.

The requirements for lines with gravity humps are essentially identical in all states except Poland.

The radii of vertical curves in connecting inclines:

- On the crest of the incline – not less than 350 m.
- On the remaining elements of the downhill section – not less than 250 m.

In accordance with the [5.16.] Instructions on Railway Infrastructure Managers (no standard documents exist), the following radii apply in Poland:

- Incline – at least 350 m.
- Decline (downhill) – at least 500 m.

Conformity assessment method: geometrical measurement.

These requirements are approved in the following documents:

Belarus	[6.3.] STN Ts-01-95 '1 520 mm Gauge Railways'
Latvia	[3.4.] 'Instructions on Routine Track Maintenance', section 2.45 and section 3.65. [1.1.] Construction Norms and Regulations (SNiP) II-39-76 '1 520 mm Gauge Railways'. Design rules section 2.7.
Lithuania	[4.4.] LST 1005384.0001 '1 520 mm Railways With Passenger Train Speeds of Up to 160 km per Hour (hr)' (Infrastructure Manager standard) [1.22.] VSN 207-89, Rules and Regulations for Design of Marshalling Facilities on the Railways of the USSR

Poland	[5.1.] Directive of the Minister of Transportation and the Maritime Economy dated 10.09.1998 (Legislative Journal No 151, p. 987, §38)
Russia	[6.3.] STN Ts-01-95 '1 520 mm Gauge Railways' [1.21.] Official Construction Standards (VSN) 56-78 Instructions on Designing Stations and Railway Junctions of the USSR
Slovakia	[7.2.] Regulations on the Slovakian Railway PTE [7.1.] Slovakian Railway PTE
Ukraine	[8.2.] TsP-0138 Instructions on the Installation and Maintenance of Ukrainian Railway Tracks, section 2.7.1. For gravity humps: SNiP 1976
Estonia	[1.21.] Official Construction Standards (VSN) 56-78 Instructions on Designing Stations and Railway Junctions of the USSR

#### Conclusion:

- The requirements for this parameter are different for general use railways in the different states. Uniform line categories will be required before a uniform 1 520 mm gauge specification can be developed.
- The parameter requirements for gravity humps are essentially identical in all states except Poland (no gravity humps). These documents and requirements (subject to minor differences in Poland) may be taken as a basis when developing uniform specifications for 1 520 mm gauge railways.

#### 5.1.6 Length of station entry and departure tracks

The requirements for minimum permitted track length of station entry and departure tracks are identical in all states except Poland and Slovakia.

The minimum permitted track lengths are as follows:

Belarus, Latvia, Lithuania, Russia, Ukraine and Estonia – 850 m

Poland – 750 m

Slovakia – 830 m

Other standard station entry and departure lengths existing for the 1 520 mm gauge system:

- According to [1.1.] Construction Norms and Regulations (SNiP) II-39-76 '1 520 mm Gauge Railways' (section 8.15): 1 250 m; 1 050 m

- According to [6.3.] STN Ts-01-95 '1 520 mm Gauge Railways': 1 050 m, 2 x 850 m, 2 x 1 050 m.

In fact, in Latvia, Lithuania and Estonia, the existing station entry and departure tracks are 850 m and 1 050 m, but these requirements are not fixed in any state regulatory document.

By agreement with the Oktyabrsky Railway, a station entry and departure tracks of 1 500 m (100 vehicle spaces, 8 000 tonne train capacity) has been created at Narva, Estonia. The project requirements were applied as a regulatory document.

Conformity assessment methods: geometric measurement.

These requirements are approved in the following documents:

Belarus	[6.3.] STN Ts-01-95 '1 520 mm Gauge Railways', section 10.15
Latvia	[1.1.] Construction Norms and Regulations (SNIIP) II-39-76 '1 520 mm Gauge Railways'. Design rules.
Lithuania	[4.6.] 'Railway Station Design Rules, 15/LG'
Poland	[5.14.] Technical Regulations for Railway Infrastructure Managers
Russia	[6.3.] STN Ts-01-95 '1 520 mm Gauge Railways' section 10.15
Slovakia	[7.2.] Regulations on the Slovakian Railway PTE [7.1.] Slovakian Railway PTE
Ukraine	[1.1.] Construction Norms and Regulations (SNIIP) II-39-76 '1 520 mm Gauge Railways'. Design rules.
Estonia	No regulatory requirements; requirements are specified in the technical assignment.

Conclusion: The requirements for this parameter are identical in all states except Poland and Slovakia. These requirements (subject to the small differences in Poland and Slovakia) and documents may be taken as the basis for developing uniform specifications for the 1 520 mm gauge system.

## 5.2 TRACK PARAMETERS

### 5.2.1 Nominal gauge

There are slight differences in requirements for this parameter.

The nominal values of gauge on straight sections of track are as follows:

- Belarus: 1 520 mm (tolerance +8 mm, -4 mm), at speed of 50 km/h (tolerance +10, -4)



- Latvia: 1 520 mm (tolerance +6 mm, -4 mm), at speed of 50 km/h (tolerance +10 mm, -4 mm)
- Lithuania: 1 520 mm (tolerance +6 mm, -4 mm)
- Poland: 1 520 mm (tolerance according to speed, see section 5.6.3)
- Russia: 1 520 mm (tolerance +8 mm, -4 mm)
- Slovakia: 1 520 mm (tolerance +8 mm, -4 mm)
- Ukraine: 1 520 mm (tolerance +8 mm, -4 mm), at speed of 50 km/h (tolerance +10 mm, -4 mm)
- Estonia: 1 520 mm (tolerance +8 mm, -4 mm) and 1 524 mm, (The 2003 Railway Act also covers 1 435 mm gauge with a view to developments)

In addition to the above values, which do not require a speed reduction, there are operational values that require a speed reduction (see 5.6.3).

Track gauge values in curves are as follows:

<b>Belarus, Russia:</b>	
Straight sections and curves with a radius of 350 m or more	1 520 mm (tolerance +8 mm, -4 mm)
Curves with a radius of 349 m to 300 m	1 530 mm (tolerance +8 mm, -4 mm)
Curves with a radius of 299 m or less	1 535 mm (tolerance +8 mm, -4 mm)
<b>Ukraine:</b>	
For track with concrete sleepers, standard gauge on straights and curves with a radius of 300 m or more	1 520 mm (tolerance +8 mm, -4 mm)
In circular curves with a radius of 200 m to 450 m	Laying of special concrete sleepers with standard gauge of 1 535 mm permitted (tolerance: +8 mm, -4 mm on curves with a radius of 300 m or more, +6 mm, -4 mm on curves with a radius of less than 300 m).

Curves with radii less than 300 m (and for standard gauge 1524 mm for radii less than 350 m):	+6 mm, -4 mm.
Curves on wooden sleepers	According to section 2.1.1 [8.2.] TsP-0138 Instructions on the Installation and Maintenance of Ukrainian Railway Tracks
<b>Latvia:</b>	
Straight sections and curves with a radius of 350 m or more	1 520 mm (tolerance +6 mm, -4 mm), at speeds up to 50 km/h (tolerance +10 mm, -4 mm)
Curves with a radius of 349 m to 300 m	1 530 mm (tolerance +6 mm, -4 mm), at speeds up to 50 km/h (tolerance +10 mm, -4 mm)
Curves with a radius of 299 m or less	1 540 mm (tolerance +6 mm, -4 mm), at speeds up to 50 km/h (tolerance +10 mm, -4 mm), but not more than 1 548 mm

Conformity assessment method: geometric measurement.

These requirements are approved in the following documents:

Belarus	[2.2.] Enterprise Standards document (STP) 09150.56.010-2005 'Routine Railway Track Maintenance. Technical Requirements and Work Management', section 5.1.18.
Latvia	[3.3.] 'PTE of the Latvian Railway', section 29, section 30 [3.4.] 'Instructions on Routine Track Maintenance', section 2.2-2.3.
Lithuania	[4.7.] 'Lithuanian Railway ' [4.1.] 'Instructions on Routine Railway Track Maintenance K/111'
Poland	[5.14.] Technical Regulations for Railway Infrastructure Managers: Id-19(D3) (AO PKP PLK - draft) LHS Id-1(D3) (OOO PKP LHS)

Russia	[6.4.] Instructions on the Routine Maintenance of Railway Tracks, TsP-774 [6.1.] PTE for Railways of the Russian Federation section 3.9.
Slovakia	[7.2.] Regulations on the Slovakian Railway PTE [7.1.] Slovakian Railway PTE
Ukraine	[8.2.] TsP-0138 Instructions on the Installation and Maintenance of Ukrainian Railway Tracks, section 2.1.1
Estonia	2003 Railways Act Instructions on track maintenance

Conclusion: The requirements for this parameter differ only slightly among the states. These documents and requirements may be taken as a basis when developing uniform specifications for the 1 520 mm gauge system.

## 5.2.2 Cant

The requirements for this parameter are identical in all states.

The cant shall not exceed 150 mm, allowing for tolerances.

Cant is required in curves with a radius of 4 000 m or less.

Conformity assessment method: instrumental (geometric measurement).

These requirements are approved in the following documents:

Belarus	[2.2.] Enterprise Standards document (STP) 09150.56.010-2005 'Routine Railway Track Maintenance. Technical Requirements and Work Management', section 5.1.2. [2.1.] PTE of the Belarusian Railway, section 3.10. [2.4.] Order Concerning the Procedure for Application of Certain Provisions of the Standard Operating procedures, the Instructions for Signalling, Train Traffic, and Shunting Operations, on the Belarusian railways, section 3.10.
Latvia	[3.3.] 'PTE of the Latvian Railway', section 31. [3.4.] 'Instructions on Routine Track Maintenance', section 2.4-2.14.
Lithuania	[4.1.] 'Instructions on Routine Railway Track Maintenance K/111'
Poland	[5.1.] Directive of the Minister of Transportation and the Maritime Economy dated 10.09.1998 (Legislative Journal No 151, p. 987, §89).

Russia	[6.3.] STN Ts-01-95 '1 520 mm Gauge Railways', section 4.23 [6.4.] Instructions on the Routine Maintenance of Railway Tracks, TsP-774
Slovakia	[7.2.] Regulations on the Slovakian Railway PTE [7.1.] Slovakian Railway PTE
Ukraine	[8.2.] TsP-0138 Instructions on the Installation and Maintenance of Ukrainian Railway Tracks, section .2.1.4
Estonia	[9.3.] RTL 2001, 129, 1870 Instructions on the application of construction gauges., paragraph 33 table 8

Conclusion: The requirements for this parameter are identical in all eight states. These documents and requirements may be taken as a basis when developing uniform specifications for the 1 520 mm gauge system.

### 5.2.3 Cant deficiency

The requirements for this parameter are identical in all states except Poland.

Belarus, Latvia, Lithuania, Russia, Slovakia, Ukraine and Estonia: Cant deficiency shall not exceed 115 mm

Poland: set depending on the placement of switches and speeds: 46 mm, 69 mm, 77 mm, 100 mm, 92 mm, 122 mm (nominal value).

Maximum cant deficiency is calculated to avoid exceeding maximum unabsorbed centrifugal acceleration in passenger trains of  $-0.7 \text{ m/s}^2$ .

The values of cant deficiency and centrifugal acceleration are calculated using the following formula:

$$h_{\text{deficiency}} = \frac{L a_{\text{cent unballanced}}}{g}$$

where:

- $h_{\text{deficiency}}$ : cant deficiency
- $L$ : distance between wheel/rail contact points
- $a_{\text{cent unballanced}}$ : unabsorbed centrifugal force
- $g$ : free fall acceleration

for 1 520 mm,  $h_{\text{deficiency}} [\text{mm}] \approx 164a_{\text{cent unbalanced}} [\text{M/c}^2]$ .

Conformity assessment method: geometric measurement and calculation.

These requirements are approved in the following documents:

Belarus	[2.2.] Enterprise Standards document (STP) 09150.56.010-2005 'Routine Railway Track Maintenance. Technical Requirements and Work Management', section 5.1.3.
Latvia	[3.4.] 'Instructions on Routine Track Maintenance', section 2.4.
Lithuania	[4.1.] 'Instructions on Routine Railway Track Maintenance K/111'
Poland	[5.1.] Directive of the Minister of Transportation and the Maritime Economy dated 10.09.1998 (Legislative Journal No 151, p. 987, § 33).
Russia	[6.4.] Instructions on the Routine Maintenance of Railway Tracks, TsP-774
Slovakia	[7.5.] STN P ENV 13803-1 Železnice. Parametre návrhu usporiadania koľaje. Rozchod 1 435 mm a širší. Časť 1: Koľaj (2004) (ENV 13803-1 Railway Applications. Track Alignment Design Parameters. Track Gauges of 1 435 mm and Wider. Plain Line)
Ukraine	[8.2.] TsP-0138 Instructions on the Installation and Maintenance of Ukrainian Railway Tracks, section .2.1.4
Estonia	Track Operating Instructions, paragraph 25

Conclusion: The requirements for this parameter are the same in all states except Poland. These documents and requirements may be taken as the basis in developing uniform specifications for the 1 520 mm gauge system (subject to minor differences in Poland).

#### 5.2.4 Rate of change of cant

The requirements for this parameter differ in different states and are set depending on line category, track category and design speed.

Belarus, Russia and Estonia: the greatest permitted rates of change of cant are determined as follows:

Cant deviation, mm/m		Established train speed, km/h
Recommended	Maximum permitted	
0.5	0.7	140
0.8	1.0	120
0.9	1.2	110

1.0	1.4	100
1.2	1.6	90
1.4	1.7	85
1.6	1.9	80
1.8	2.1	75
1.9	2.3	70
2.0	2.5	65
2.1	2.7	60
2.3	2.9	55
2.5	3.0	50
2.7	3.1	40
3.0	3.2	25
	More than 3.2	Closed to trains

Ukraine: maximum permitted rates of change of cant are determined as follows:

Cant, mm/m		Established train speed, km/h
Recommended	Maximum permitted	
0.5	0.7	140
0.7	1.0	120
0.8	1.2	110
1.0	1.4	100
1.2	1.6	90
1.4	1.9	80
1.6	2.3	70
1.9	2.7	60
2.2	3.0	50
2.5	3.1	40
2.8	3.5	25
3.0	4.5	15
	More than 4.5	Closed to trains

Latvia: for sections of track with passenger and refrigerated train speeds of up to 120 km/h and freight train speeds of up to 80 km/h, the permitted rate of change of cant is 1

mm/m, and up to 3 mm/m in difficult conditions. Additional requirements for track construction and maintenance on lines with higher speed trains may be set by a separate instruction from the infrastructure manager.

Lithuania: the permitted rate of change of cant is 1 mm/m. Up to 3 mm/m is permitted in difficult conditions by special permission of the Lithuanian Railway Administration.

The rate of change of cant may be expressed as 'speed of change' (mm/s) for the maximum permitted speed of trains. This value is derived using the following formula: Rate of change [mm/s] = Rate of change [mm/m] x V [m/s]

Poland: rate of change of cant is determined using the formula  $100/V$  or  $125/V$  mm/m, where V is maximum speed in km/h.

Slovakia: values are set according to STN P ENV 13803-1 Železnice. Parametre návrhu usporiadania koľaje. Rozchod 1 435 mm a širší. Časť 1: Koľaj (2004) (ENV 13803-1 Railway Applications. Track Alignment Design Parameters. Track Gauges of 1 435 mm and Wider. Plain Line).

Conformity assessment methods: geometric measurement and calculation.

These requirements are approved in the following documents:

Belarus	[2.2.] Enterprise Standards document (STP) 09150.56.010-2005 'Routine Railway Track Maintenance. Technical Requirements and Work Management' section 5.1.7.
Latvia	[3.4.] 'Instructions on Routine Track Maintenance', section 2.1, 2.6-2.12.
Lithuania	[4.1.] 'Instructions on Routine Railway Track Maintenance K/111'
Poland	[5.1.] Directive of the Minister of Transportation and the Maritime Economy dated 10.09.1998 (Legislative Journal No 151, p. 987, §34, table 3.11).
Russia	[6.4.] Instructions on the Routine Maintenance of Railway Tracks, TsP-774, section 2.1.6.
Slovakia	[7.2.] Regulations on the Slovakian Railway PTE [7.1.] Slovakian Railway PTE [7.5.] STN P ENV 13803-1 Železnice. Parametre návrhu usporiadania koľaje. Rozchod 1 435 mm a širší. Časť 1: Koľaj (2004) (ENV 13803-1 Railway Applications. Track Alignment Design Parameters. Track Gauges of 1 435 mm and Wider. Plain Line)
Ukraine	[8.2.] TsP-0138 Instructions on the Installation and Maintenance of Ukrainian Railway Tracks, section 2.1.6
Estonia	Track Maintenance Instructions





R 65 ([1.9.] GOST 8161-75 'R65 Type Railway Rails. Design and Dimensions')	R 50
--	------

[Key, top to bottom: R65, RP65 Rail; Centre line; Centre line of bolt holes]

[Key, top to bottom: R50, RP50 Rail; Centre line; Centre line of bolt holes]

Conformity assessment method: manufacturer certificate of conformity.

These requirements are approved in the following documents:

Belarus	[1.9.] GOST 8161-75 'R65 Type Railway Rails. Design and Dimensions' [2.3.] SNB 3.03.01-98 '1 520 mm Railways' [2.2.] Enterprise Standards document (STP) 09150.56.010-2005 'Routine Railway Track Maintenance. Technical Requirements and Work Management'
Latvia	[3.11.] Cabinet of Ministers Regulations No 566
Lithuania	[4.1.] 'Instructions on Routine Railway Track Maintenance K/111' [4.4.] LST 1005384.0001 '1 520 mm Railways With Passenger Train Speeds of Up to 160 km per Hour (hr)', [4.5.] LST 1005384.0002 'Track Structure of 1 520 mm Gauge Railways with Passenger Train Speeds of Up to 160 km/h'
Poland	[5.14.] Technical Regulations for Railway Infrastructure Managers
Russia	[6.3.] STN Ts-01-95 '1 520 mm Gauge Railways', section 6 [6.4.] Instructions on the Routine Maintenance of Railway Tracks, TsP-774, Annex 1
Slovakia	[7.2.] Regulations on the Slovakian Railway PTE [7.1.] Slovakian Railway PTE
Ukraine	[8.3.] DSTU 4344:2004 Standard Rails for Broad-Gauge Railways. General Specifications [8.2.] TsP-0138 Instructions on the Installation and Maintenance of Ukrainian Railway Tracks, annex 2
Estonia	[9.5.] Estonian Railways PTE, paragraph 28

Conclusion: The requirements for this parameter differ only slightly among the states. These documents and requirements may be taken as a basis when developing uniform specifications for the 1 520 mm gauge system.

### 5.2.6 Equivalent conicity

The parameter of equivalent conicity in the 1 520 mm gauge system is not determined or standardised at present. The parameters are currently considered separately.

The matter is under study in Russia, and the approach being taken conforms to the approach in the TSI, however it has yet to be approved as a standard. The new complex approach will consider all parameters together: wheel profile, railhead profile, rail incline, etc.

See section 5.2.7 Rail inclination.

Conclusion: this parameter requires further study.

### 5.2.7 Rail inclination

The requirements for this parameter are identical in all states except Poland.

Country	Nominal value	Tolerance
Belarus, Lithuania, Latvia, Russia, Slovakia, Estonia	1/20	Not less than 1/60 or more than 1/12  For cant of more than 85 mm – 1/30 and 1/12, respectively
Poland	1/20 and 1/40 (for 49E1 rails) 1/40 (R65 and 60E1 rails) 1/∞ and 1/40 (in turnouts)	
Ukraine	1/20	+1/30, -1/30 (in all cases in straight and curved sections with cant up to 150 mm, the incline shall not be less than 1/60 or more than 1/12)

In the case of the deviations indicated for Ukraine, the difference is only in the form in which the values are presented, rather than the actual values.

Conformity assessment method: geometric measurement.

These requirements are approved in the following documents:

Belarus	[2.2.] Enterprise Standards document (STP) 09150.56.010-2005 'Routine Railway Track Maintenance. Technical Requirements and Work Management', section 6.1.3.
Latvia	[3.4.] 'Instructions on Routine Track Maintenance', section 2.26.

Lithuania	[4.1.] 'Instructions on Routine Railway Track Maintenance K/111'
Poland	[5.1.] Directive of the Minister of Transportation and the Maritime Economy dated 10.09.1998 (Legislative Journal No 151, p. 987, §22).
Russia	[6.4.] Instructions on the Routine Maintenance of Railway Tracks, TsP-774
Slovakia	[7.2.] Regulations on the Slovakian Railway PTE [7.1.] Slovakian Railway PTE
Ukraine	[8.2.] TsP-0138 Instructions on the Installation and Maintenance of Ukrainian Railway Tracks, section 2.2.8
Estonia	[9.14.] Railway Track Technical Maintenance Instructions

Conclusion: The requirements for this parameter are the same in all states except Poland. These documents and requirements may be taken as the basis for developing uniform specifications for the 1 520 mm gauge system (subject to the minor differences in Poland).

### 5.2.8 Track Stiffness

Vertical stiffness  $C_z^0$  (N/m) is the ratio of vertical force applied to the centre of the railhead to vertical deflection at the point at which that force is applied. The notion of vertical foundation linear stiffness  $C_z^0$  (N/m<sup>2</sup>) applies to the under-rail base. This stiffness is often referred to as the track modulus of elasticity. The track modulus of elasticity is the reaction of the foundation per unit of length to deformation of the foundation equal to one unit. Track stiffness may be static or dynamic. Changes in stiffness along the length of the track are of a random nature.

Belarus: in engineering calculations, track is treated as an infinite bar on an uninterrupted, equally elastic base. The optimum track elasticity for track on concrete sleepers is 50-100 MPa on an annual cycle. This baseline modulus of elasticity applies to the total track structure: fastenings – sleepers – ballast – earthworks.

Latvia: parameter not standardised. In practice, requirements for track components and construction apply (earthworks, ballast prism, fastenings, etc.).

Russia: the intermediate fastenings and foundation modulus are standardised in the 1 520 mm gauge system.

The coefficient of proportionality between the linear load and the elastic compression of the foundation is referred to as the rail foundation modulus of elasticity. It is numerically equal to the equally distributed load applied to a unit of length of rail causing elastic compression by a unit of length.

Ukraine: absent experimental data, determined theoretically depending on upper track structure and particulars of use.

The baseline modulus of elasticity for the under-rail foundation of track on concrete sleepers varies from 60-110 MPa, and for track with wooden sleepers from 20-40 MPa. This baseline modulus of elasticity applies to the track structure as a whole: fastenings – sleeper – ballast - earthworks.

Conformity assessment method: calculation, experimental studies (using modulation car).

These requirements are approved in the following documents:

Belarus	Design documents
Latvia	Not standardised.
Lithuania	Used in design, not tested in operation. Parameter not standardised [1.57.] Track Engineer's Handbook, Volume I (information document)
Poland	Used in design, not tested in operation. Directive of the Minister of Transport and the Maritime Economy of 10.09.1998 legislative journal No 151, p. 987, paragraph 16 (Roadbed only)
Russia	Not standardised Rigidity of elastic intermediate fastenings and foundation modulus of elasticity are standardised. (M. Shakhunyants textbook, 1961, p. 495)
Slovakia	Used in design, not tested in operation. Not standardised Instruction C3 Track Structure No 25805/76
Ukraine	[8.9.] TsP-0117, Rules for Calculating Railway Track Strength and Stability, section 2.3.9 M. Shakhunyants textbook, 1961, p. 495, section on track modulus of elasticity used for calculations
Estonia	Used in design, not tested in operation. Not standardised

Conclusion: this parameter requires further in-depth study.

### 5.2.9 Electrical insulation of rails

The requirements for this parameter are identical in all eight states (with minor differences in Poland).

On automatic blocking sections, the rails are used to carry current. Insulating rail connections divide the automatic blocking rails into individual, insulated blocks.

The minimum baseline specific resistance of the ballast shall be:

- 1 Ohm·km for two-rail track circuits
- 0.5 Ohm·km for single rail and branching track circuits
- 0.1 Ohm·km for audio frequency track circuits

The resistance of functioning insulating joints, switchgear, and other elements varies from 100 Ohm to several thousand Ohm, with insulation unsuitable for use having a resistance of not less than 50 Ohm.

Specific resistance of insulation of track circuit for maximum lengths:

- minimum – 0.5 Ohm·km (Poland – 1.0 Ohm·km for track);
- maximum – 50 Ohm·km.

The electrical resistance of rail joints on DC lines shall be: for 12.5 m rails, not more than 3 m of rail (not more than 100  $\mu$ Ohm); for longer and equalizing rails of continuous track – 6 m of rail (not more than 200  $\mu$ Ohm).

Conformity assessment method: electrical measurement.

These requirements are approved in the following documents:

Belarus	[2.5.] STP 09150.19.058-2007 'Maintenance Requirements for Signalling, Control, and Interlock Devices', section 10.4
Latvia	[1.31.] 'Automation and Remote Control Devices on Railway Vehicles, Departmental Process Design Standards (VNTP)/MPS-85'
Lithuania	Industry technological design standards [4.9.] 'Rules on the Technological Design of Railway Signalling Devices', 25/AA
Poland	[5.1.] Directive of the Minister of Transportation and the Maritime Economy dated 10.09.1998 (Legislative Journal No. 151, p. 987, § 57)
Russia	[6.8.] Signal Boxes (STsB). Maintenance. Technological Design

	Standards (NTP) STsB/MPS-99 [6.9.] Instructions on the Maintenance of Signal Boxes, No TsSh-720 dated 20.12.1999
Slovakia	[7.2.] Regulations on the Slovakian Railway PTE
Ukraine	[8.10.] TsShEOT-0012 Instructions on the technical servicing of , section 10.8
Estonia	[6.9.] Instructions on the Maintenance of Signal Boxes, No TsSh-720 dated 20.12.1999

Conclusion: The requirements for this parameter are the same in all states, except minor differences in Poland. These documents and requirements may be taken as a basis for developing uniform specifications for the 1 520 mm gauge system (subject to minor differences in Poland).

### 5.3 REQUIREMENTS FOR SWITCHES AND CROSSINGS

#### 5.3.1 Means of Locking

The requirements for means of locking differ in different states. Nevertheless, in all eight states some means of locking is mandatory.

Conformity assessment method: visual, instrumental measurement.

These requirements are approved in the following documents:

Belarus	[2.3.] SNB 3.03.01-98 '1 520 mm Railways', section 5.17 [2.2.] Enterprise Standards document (STP) 09150.56.010-2005 'Routine Railway Track Maintenance. Technical Requirements and Work Management', section 6.5
Latvia	[3.3.] 'PTE of the Latvian Railway' section 117, 126
Lithuania	[4.7.] 'Lithuanian Railway '
Poland	[5.14.] Technical Regulations for Railway Infrastructure Managers
Russia	[6.1.] PTE for Railways of the Russian Federation
Slovakia	[7.2.] Regulations on the Slovakian Railway PTE [7.1.] Slovakian Railway PTE
Ukraine	[8.11.] Technological Design Rules for Automation and Telemechanical Devices on Ukrainian Railways, No 105-Ts of 17.04.2003., section 3.6
Estonia	Documents regulating SCB and electrical. To be clarified.

Conclusion: means of locking are mandatory in all eight states. These documents and requirements may be taken as a basis when developing uniform specifications for the 1 520 mm gauge system.

### **5.3.2 In service geometry of switches and crossings**

There are minor differences in requirements for this parameter.

#### **5.3.2.1 Frog number**

Belarus, Latvia, Lithuania, Russia, Ukraine and Estonia: turnouts must use the following frogs:

Main lines and station entry and departure tracks – not more than number 1/11, crossings and single switches continuing from crossings – not more than number 1/9 (passenger trains switching to sidings on number 1/9 turnout is permitted if replacement with number 1/11 would require reconstruction of switch flangeways);

Station entry and departure tracks for freight trains – not more than number 1/9, for symmetric track – not more than number 1/6.

Poland: main tracks: number 1:9 or less.

Slovakia: main tracks: number 1:9.

#### **5.3.2.2 Maximum turnout variables at which traffic is halted**

Latvia, Lithuania, Russia, Ukraine and Estonia: Critical maximum turnout variables at which traffic through the switches is halted (use is banned) are set forth in standard operating instructions. Switches and crossings cannot be operated if even one of the following defects is present:

1. Blades and moving frogs separate from pins;
2. Blades separates from guide rail or frog from check rail by 4 mm or more. Separation of the blade or frog is measured:
  - Latvia: at the first pin, or if the pin on a swingnose frog is before the frog switches, at the frog switches.

- Ukraine: at the first pin of the switches and swingnose frog of a blunt nose switch or facing swingnose frog of a edged nose switch – 150 mm from the start of switches (locked switch or frog)
3. Pitting of the switches or frog creating a risk of rolling of the flange over the rail, and in all cases of pitting with a length of:
    - Main lines – 200 mm or more (Ukraine: depth of 5 mm or more);
    - Station entry and departure tracks – 300 mm or more (Ukraine: depth of 8 mm or more);
    - Other station tracks – 400 mm or more (Ukraine: depth of 10 mm or more)
  4. Lowering of the blade against the running rail, or moving frog against the check rail, by 2 mm or more, measured at the section where the blade or frog is 50 mm or more in width in the upper part.
  5. Distance between gauge faces of frog and check rail: not less than 1 472 mm.
  6. Distance between gauge faces of check rail and wing rail: not more than 1 435 mm.
  7. Broken switch or running rail, broken crossing (frog, check rail, wing rail).
  8. Shearing of check rail bolt in single bolt, or two in two bolt inserts.
  9. Ukraine: no detector bar on non-centralised switches, or blade contact detector at first pin, so that distance between blade and guide rail is 4 mm or more.

Latvia, Lithuania, Russia, Ukraine and Estonia: blade step (separation of second (non-gauge) switch blade from running rail) and swingnose frog step is measured at first pin between side gauge face and head of running rail or check rail and non-gauge face of switch blade or frog.

Latvia, Lithuania and Estonia: separation of second (non-gauge) switch blade from running rail ('switch blade step') on centralised (electrically actuated, for electrical centralisation) switches: not less than 125 mm.

Latvia, Lithuania and Estonia: 152 mm with tolerances of +8 mm, -2 mm. But including lift in pins and the particulars of electrical actuators, the minimum is 147 mm, provided the minimum flange width between the running rail and the stepped switch blade is not less than 65 mm. In general for non-centralised (manually operated) and centralised switches, the switch blade step is kept between 150 mm and 160 mm.



Russia: switch blade step – not less than 147 mm.

Ukraine: standards and tolerance in switch blades' steps

Construction	Standard step, mm	Tolerance, mm
Common, symmetrical and crossing switches	152	+8, -2
Swingnose frog	140	+4, -2
Blunt nose crossing	84	+4, -2

### 5.3.2.3 Other geometric characteristics of switches and crossings

General layout of turnout:



Рис. 31. Места контрольных измерений ширины колеи на стрелочном переводе и желобов на стрелке и в контрольсах

[Fig. 31 Locations of control measurements of gauge in switches, at flangeways and at check rail. Key (L-R): Check rail curve (only for switches with curve checks); hinge of blades; end of switch curve; start of frog; frog nose cross-section.]

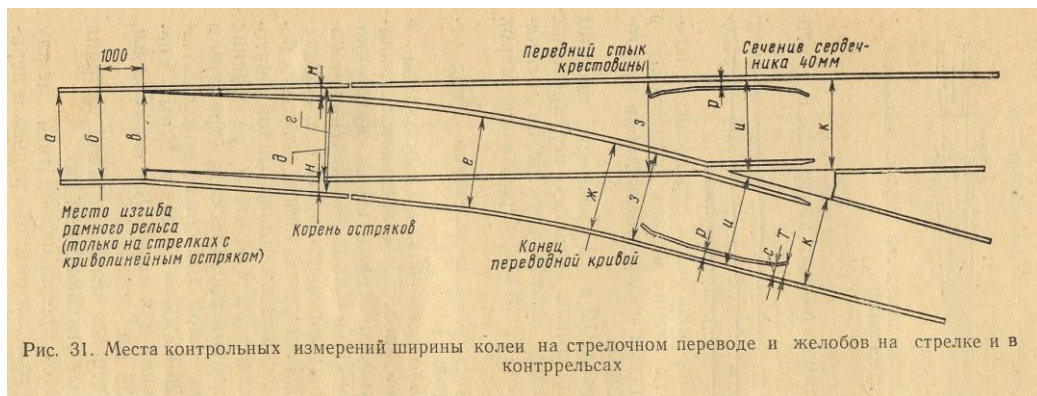
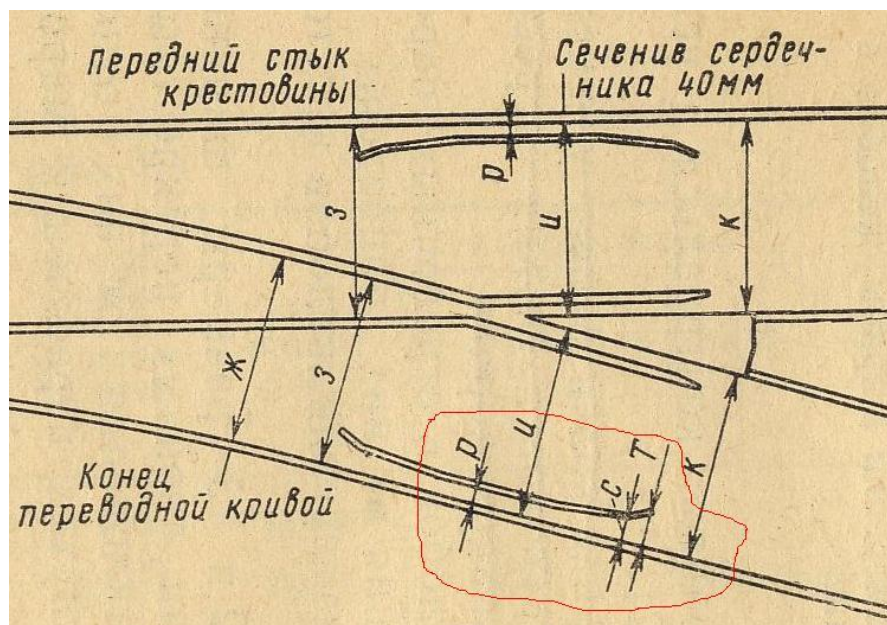

[Detail of Fig. 31.]

Latvia, Lithuania, Russia and Estonia: the following parameters are regulated (presented in the table according to type of switch):

Parameter		Nominal value	Tolerance
T	Flangeway width at counter rail on entry	86 mm	Latvia, Estonia: +6 mm -2 mm Lithuania: +3 mm -2 mm
C	Flangeway width at counter rail lead part	64 mm	Latvia, Estonia: +5 mm -2 mm Lithuania: +3 mm -2 mm
P	Flangeway width at straight section of counter rail	44 mm	Latvia, Estonia: +3 mm -2 mm Lithuania: +2 mm -2 mm

### Frog

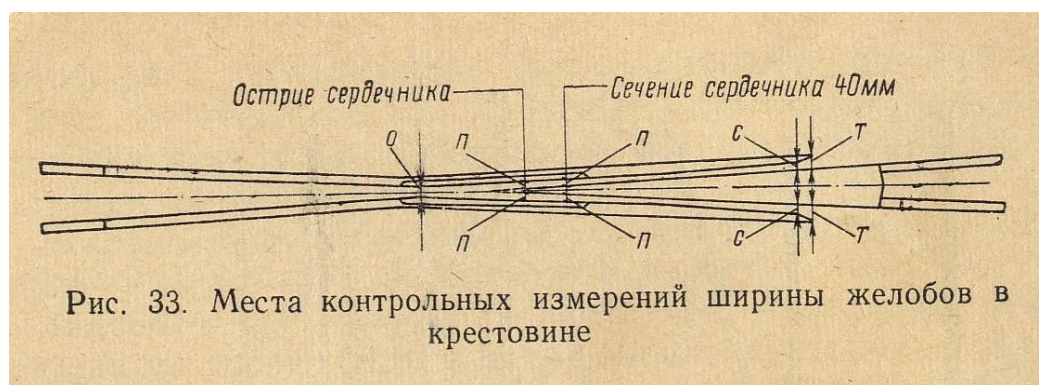

[Fig. 33. Control measurements of flangeway width in frog. (L-R): Frog nose; Frog nose cross-section.]

Latvia, Lithuania: the following parameters are regulated (presented in table according to frog mark):

Parameter		Nominal value	Tolerance
T	Flangeway width at check rail on entry	86 mm	Latvia, Estonia: +6 mm -2 mm Lithuania: +3 mm -2 mm
C	Flangeway width at check rail in lead section	64 mm	Latvia, Estonia: +5 mm -2 mm Lithuania: +3 mm -2 mm
П	Flangeway width at switch and to centre of frog	40-46 mm	+2 mm -2 mm
O	Flangeway width at mouth of frog	Latvia: 64 mm Lithuania: 62 mm Estonia: 64 mm	Latvia, Estonia: +6 mm -2 mm Lithuania: +3 mm -2 mm

Blunt nose frog in double crossing switch (example of number 1/9 blunt nose frog)

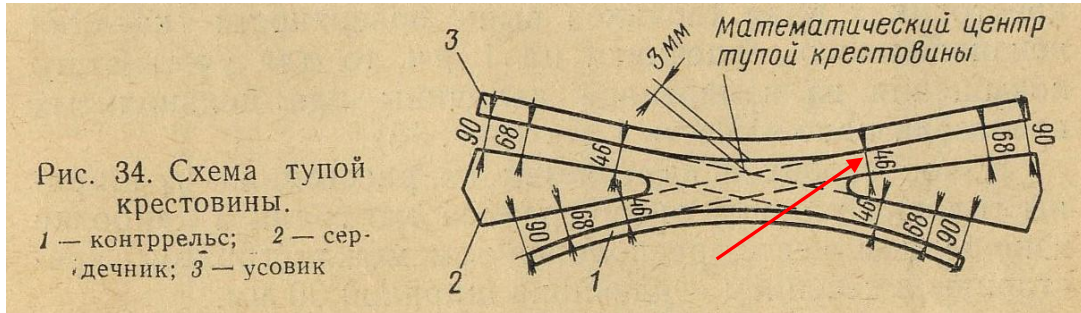

[Fig. 34. Blunt nose frog. 1. Counter rail; 2. nose; 3. check rail; Mathematical center of frog (intersection).]

Latvia, Lithuania: the following parameters are regulated:

Parameter	Nominal value	Tolerance
Flangeway width at throat (straight section of check rail)	45 mm	+3 mm -2 mm

Vertical wear on frog elements is monitored depending on type of switches:

Latvia: for 40 mm section frogs, maximum permitted wear is 12 mm (speed restricted to 40 km/h).

Lithuania: main lines – 6 mm, marshalling yards – 8 mm, other lines – 10 mm.

The initial measuring point for wear is the non-gauge face of the check rail, which the callipers should be resting on during measurement:

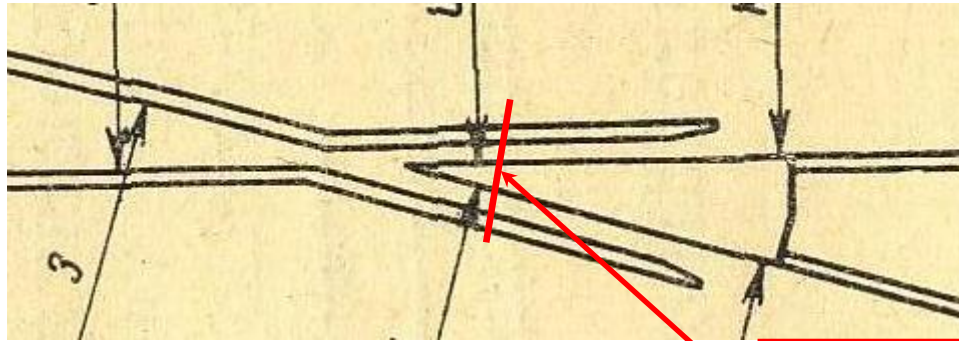

Measuring wear on frog:

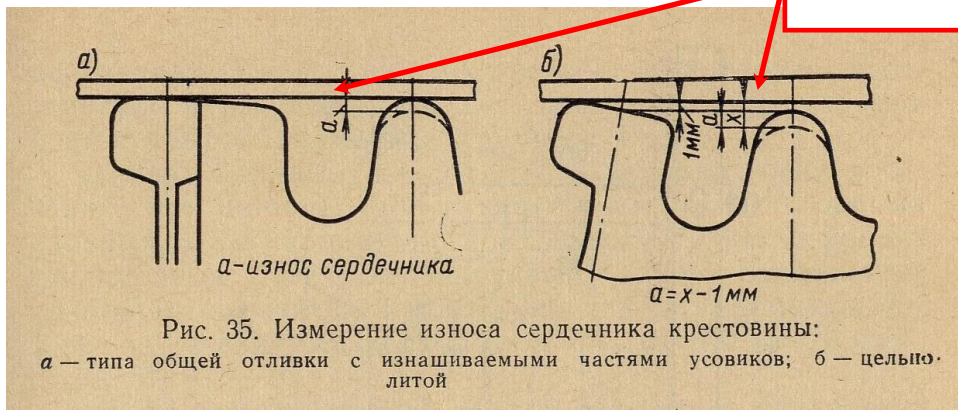

[Fig. 35. Measuring wear on frog nose. a – standard casting with wear to parts of check rail; b – single-piece casting]

Measuring wear on check rail:

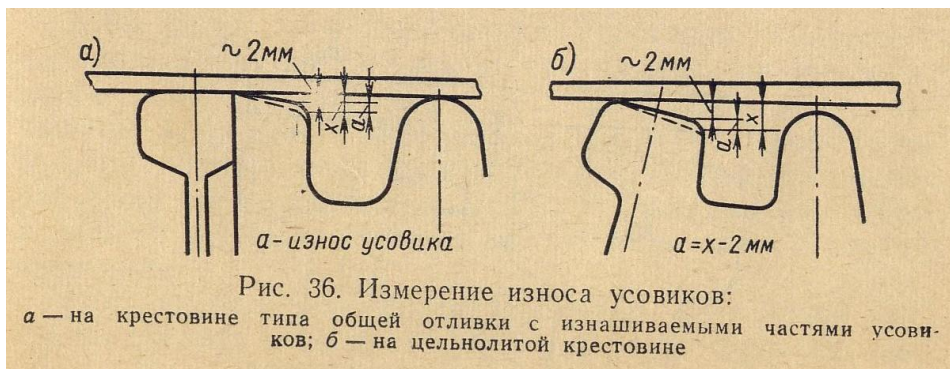

[Fig. 36. Measuring wear on check rail. a – standard casting with wear to parts of check rail; b – single-piece casting]

In accordance with [1.20.] 'Instructions of the Ministry of Railways (MPS) of the Union of Soviet Socialist Republics (USSR). TsP-2913 Dated 8 June 1971' (table 17), vertical wear on check rails between the throat and the 30 mm section of the frog is also regulated – maximum wear is 10 mm.

In [3.4.] 'Instructions on Routine Track Maintenance', vertical wear of check rails is not regulated. The reason for this is that, in practice, the frog wears faster and, as a rule, the crossing is rejected because of wear to the frog rather than the check rail. That is, in practice this parameter is not necessary.

Lithuania: permitted vertical wear on the check rail is the same as for the frog (6, 8 and 10 mm) as [4.1.] 'Instructions on Routine Railway Track Maintenance K/111' section 5.11.8.

Ukraine: flange width and tolerance in crossings and switches are specified in table 2.21 section 2.10.4 of [8.2.] TsP-0138 Instructions on the Installation and Maintenance of Ukrainian Railway Tracks:

Flangeways' width measuring point	Standard flangeway width, mm	Tolerance, mm
Throat of frog:		
- fixed	64	+6,-2
- swingnose		
o Dn 060	139	+6,-2
o Dn 300,400	137	+6, -2
Straight section of check rail of edged frog	44	+3, -2
Straight section of check rail from 20 mm frog section to 50 mm section frog	46	+3, -2
Same for blunt nose	45	+3, -2
At entry to lead section of counter rail and check rail of edged or blunt nose frog	64	+5, -2
At mouth of counter rail and check rail for edged and blunt frogs, the same for check rail	86	+6, -2

Ukraine: the maximum permitted vertical and lateral wear on turnouts is set out in table 2.26 of section 2.10.16 of [8.2.] TsP-0138 Instructions on the Installation and Maintenance of Ukrainian Railway Tracks:

Turnout component	Passenger trains, speed >120-140 km/h	Freight trains, speed >80-90 km/h	Passenger trains, speed >100-120 km/h	Passenger trains under 100 km/h, freight trains under 80 km/h	All trains under 40 km/h	R43 and lighter
	UIC-60, R65		UIC-60, R65, R50			

Vertical wear							
Running rails	5	8	6	8	10	12	10
Switch blades	5	8	6	8	10	12	10
Frog at 40 mm section and check rail at point of greatest wear	5	6	5	6	8 (R50) 10 (R65 and UIC60)	10 (R50) 12 (R65 and UIC60)	10
Connecting track rails	6	9	10	10 (R50)	10 (R50)	10 (R50)	
				12 (R65 and UIC60)	13 (R65 and UIC60)	13 (R65 and UIC60)	10
Lateral wear							
Running rails and switch blades at point of greatest wear	5	8	6	8	8	11	11
Running rails at switch point	5	6	6	6	6	6	6

Conformity assessment method: geometric measurement.

These requirements are approved in the following documents:

Belarus	[2.3.] SNB 3.03.01-98 '1 520 mm Railways', section 5.17 [2.2.] Enterprise Standards document (STP) 09150.56.010-2005 'Routine Railway Track Maintenance. Technical Requirements and Work Management', section 6.5
Latvia	[3.3.] 'PTE of the Latvian Railway', section 34, 38, 117.3 [3.4.] 'Instructions on Routine Track Maintenance' section 2.84, section 2.87, section 2.93 (based on sections 75 and 79, respectively of [1.20.] 'Instructions of the Ministry of Railways (MPS) of the Union of Soviet Socialist Republics (USSR). TsP-2913 Dated 8 June 1971')
Lithuania	[4.1.] 'Instructions on Routine Railway Track Maintenance K/111', chapter 5.11. [4.7.] 'Lithuanian Railway ' section 5.4 [4.14.] LST EN 13262, Standardisation Document SD13 (This document regulates production and requirements for new switches)
Poland	[5.14.] Technical Regulations for Railway Infrastructure Managers
Russia	[6.1.] PTE for Railways of the Russian Federation [6.4.] Instructions on the Routine Maintenance of Railway Tracks, TsP-774
Slovakia	[7.1.] Slovakian Railway PTE

Ukraine	[8.1.] Ukrainian Railway PTE, section 3.14. [8.12.] Railway connections and intersections, general specifications SOU 45.080-00034045-002:2007 [8.2.] TsP-0138 Instructions on the Installation and Maintenance of Ukrainian Railway Tracks, section 2.10.4, table 2.21, section 2.10.5, table 2.22, section 2.10.6, table 2.26.
Estonia	[9.5.] Estonian Railways PTE, paragraph 29, same indicators as for other traffic 1/8, 1/4.5.

Conclusion: The requirements for this parameter differ only slightly among the states. These documents and requirements may be taken as a basis when developing uniform specifications for the 1 520 mm gauge system.

### 5.3.3 Maximum unguided length of fixed obtuse crossings

At present, the requirements for this parameter are as follows:

Belarus, Russia and Ukraine: throat to mathematical centre of frog:

- R65 1/11-683 mm
- R65 1/9-560 mm

Latvia, Lithuania and Estonia: parameter not regulated, there is a requirement to cover this space with a counter rail. As standardised solutions are in use (unguided length depends on mark of frog), this parameter is not monitored in operation.

Poland: maximum unguided length is the result of movement of number 1:9 blunt nose frogs and guide devices with a height of 44 mm over the rolling surface.

Slovakia: parameter not regulated.

Conformity assessment method: geometric measurement.

These requirements are approved in the following documents:

Belarus	[2.2.] Enterprise Standards document (STP) 09150.56.010-2005 'Routine Railway Track Maintenance. Technical Requirements and Work Management', section 6.5
Latvia	Not regulated, requirements for coverage of unguided length with guide rails during design.
Lithuania	Not regulated, requirements for coverage of unguided length with guide rails during design.

Poland	[5.8.] Id-4 (D-6) 'Instructions on Switch Service Inspections and Maintenance'
Russia	[6.4.] Instructions on the Routine Maintenance of Railway Tracks, TsP-774
Slovakia	Not standardised
Ukraine	[8.2.] TsP-0138 Instructions on the Installation and Maintenance of Ukrainian Railway Tracks Table D.5.9
Estonia	Not regulated, requirements for coverage of unguided length with guide rails during design. Defect list

Conclusion: The requirements for this parameter differ in different states and are not regulated in all states. These documents and requirements may be taken as a basis when developing uniform specifications for the 1 520 mm gauge system.

## 5.4 TRACK RESISTANCE TO APPLIED LOADS

### 5.4.1 Track resistance to vertical loads

The requirements for this parameter are different in different states.

The vertical load of the wheels on the track comprises static wheel pressure and the dynamic load added by vibration and the mass of the rolling stock.

Belarus, Russia:

According to design and construction/reconstruction rules:

axle – 245 kN;

linear – 103 kN/m.

According to operating standards:

Axle load of a four-axle semi-car – 230 kN;

Dynamic linear load of car on track – 168 kN/m.

Latvia: 23.5 t per axle

Lithuania: 225 kN per axle (in special cases, rolling stock with an axle load of up to 25.0 t is permitted).

Poland: 24.5 t per axle on LHS, 22.5 t per axle on other 1 520 mm lines.



Slovakia: 24.5 t per axle, 9 t per linear metre

Ukraine: Baseline static axle load according to [1.15.] GOST 22780 'Axles for 1 520 (1 524) mm Gauge Railway Vehicles. Types, Parameters, and Sizes', 23.5 t per axle. Recommended permitted linear track load: static up to 103 kN/m, dynamic up to 168 kN/m.

Estonia: On the basis of the SNiP, designs assume locomotives with an axle load of 31.0 t per axle, and freight cars at 25.0 t per axle, regardless of line category.

Conformity assessment method: calculation, experimental measurement.

These requirements are approved in the following documents:

Belarus	[6.3.] STN Ts-01-95 '1 520 mm Gauge Railways', section 1.1.
Latvia	[3.13.] Railway Network Statement, section 3.2.2, updated annually
Lithuania	[4.4.] LST 1005384.0001 '1 520 mm Railways With Passenger Train Speeds of Up to 160 km per Hour (hr)'
Poland	[5.1.] Directive of the Minister of Transportation and the Maritime Economy dated 10.09.1998 (Legislative Journal No 151, p. 987, section 13)
Russia	[6.3.] STN Ts-01-95 '1 520 mm Gauge Railways' section 1.1. [6.5.] Order No 41 of the Railways Ministry dated 12.11.2001 'Standard Speed Limits for Rolling Stock on the 1 520 (1 524)-mm Gauge Railway Tracks of Federal Railway Transportation'
Slovakia	[7.2.] Regulations on the Slovakian Railway PTE [7.1.] Slovakian Railway PTE
Ukraine	[8.13.] Rules for calculation and design of 1 520 mm gauge rail cars, section 1.8
Estonia	In accordance with the SNiP, designs assume locomotives with an axle load of 31.0 t per axle. Regardless of line category.

Conclusion: The requirements for this parameter are different in different states. These documents and requirements may be taken as a basis when developing uniform specifications for the 1 520 mm gauge system.

#### 5.4.2 Longitudinal track resistance

The requirements for this parameter are different in different states.

Temperature forces affect the rail-sleeper grid (temperature expansion of the rails), which are resisted by friction in fastenings and supports. These temperature forces arise for

climatic reasons, and due to use of braking systems as the kinetic energy of the train is transformed into heat in the rails (electromagnetic braking, eddy current brake).

The rail-sleeper grid is subject to longitudinal forces as a result of braking.

Longitudinal stability is assessed by calculation:

1. Longitudinal forces shall not exceed the force of resistance to sleeper displacement in the ballast;
2. The longitudinal load shall not exceed the resistance force in the fastenings.

Latvia, Lithuania: On continuous track, fastenings should ensure sufficient resistance to longitudinal displacement of fastenings (25-30 kN/m).

Latvia (section 2.38 Railway Track Maintenance Instructions) and Russia (TsP 774 Track Maintenance Instructions, section 3.1.13): standard requirements apply to fixing track against creep using anti-creep springs (quantity per track zone is standardised). The standards are differentiated for braking and non-braking sections of track. Each anti-creep spring holds the track with a force of 4.9-5.9 kN.

Russia: Routes are calculated using direct longitudinal tensile and compressive forces depending on the type and load (axle load) of the rolling stock.

Poland: Minimum 7 kN – 9 kN regardless of speed.

Ukraine: maximum permitted acceleration of the rolling stock is 0.5 to 1.0 m/s<sup>2</sup>.

Latvia, Russia and Ukraine: no restrictions on use of braking systems based on transforming the kinetic force by heating the rails (electromagnetic brake, eddy current brake) (these braking systems are not currently in use in Latvia, and in Russia magnetic brakes are used only on express and high-speed lines).

Conformity assessment method: calculation, geometric measurement (rail and sleeper displacement).

These requirements are approved in the following documents:

Belarus	Not standardised.
Latvia	[3.4.] 'Instructions on Routine Track Maintenance' section 2.38 (in accordance with [1.20.] 'Instructions of the Ministry of Railways (MPS) of the Union of Soviet Socialist Republics (USSR). TsP-2913 Dated 8 June 1971', section 30, table 7)  [6.15.] Instructions of the Railways Ministry of Russia dated 31.03.2000 'Technical Instructions on the Installation, Laying, Maintenance, and Repair of a Continuous-Welded Track', section 2.7.1

	(used by the Infrastructure Manager for information purposes)
Lithuania	[4.5.] LST 1005384.0002 'Track Structure of 1 520 mm Gauge Railways with Passenger Train Speeds of Up to 160 km/h'
Poland	[1.24.] PN-EN 13146-1:2003 (U): PN-EN 13481-2:2004, Method for Inspecting Fastening Systems, Part 1 [5.13.] PN-EN 13481-2:2004 Method for Inspecting Stabilisation Systems, part 1 (Definition of track longitudinal resistance)
Russia	[6.15.] Instructions of the Railways Ministry of Russia dated 31.03.2000 'Technical Instructions on the Installation, Laying, Maintenance, and Repair of a Continuous-Welded Track', section 2.7.1 [6.4.] Instructions on the Routine Maintenance of Railway Tracks, TsP-774, section 3.1.13
Slovakia	[7.2.] Regulations on the Slovakian Railway PTE [7.1.] Slovakian Railway PTE
Ukraine	[8.9.] TsP-0117, Rules for Calculating Railway Track Strength and Stability section 3.1
Estonia	Not standardised. Regulated by companies.

Conclusion: The requirements for this parameter are different in different states. This parameter requires additional study for development of uniform specifications for 1 520 mm gauge system.

### 5.4.3 Lateral track resistance

The requirements for this parameter are different in different states.

Lateral forces on the rail sleeper grid during train movement may be dangerous to train movement.

Belarus, Russia: Lateral load subject to strength of individual rail fastenings on track and switches is 100 kN.

Latvia, Lithuania, Poland, Slovakia, and Estonia: this parameter is not standardised. In practice, requirements apply to the ballast (wall gradient, shoulder width, etc., depending on traffic density, sleeper type and curve radius).

Lithuania: earthworks to be designed in accordance with the [4.16.] 'Instructions on Railway and Highway Roadbed Design' SN 449-72'.

Poland, Slovakia, and Estonia: not standardised.

Ukraine: Lateral shift resistance of one sleeper absent a train may vary from 2-6 kN.

Lateral force: must not exceed 100-140 kN (first value is for unstabilised ballast, the second is for standard ballast).

Lateral track stability is assessed by calculation:

1. Maximum rail force shall not exceed the maximum resistance of the rail-sleeper grid to lateral shifting;
2. Horizontal lateral forces shall not cause residual shifting of the rails.

Conformity assessment method: calculation, geometric measurement (rail/sleeper displacement).

These requirements are approved in the following documents:

Belarus	[6.5.] Order No 41 of the Railways Ministry dated 12.11.2001 'Standard Speed Limits for Rolling Stock on the 1 520 (1 524)-mm Gauge Railway Tracks of Federal Railway Transportation'
Latvia	Not standardised [3.4.] 'Instructions on Routine Track Maintenance' annex 3 (ballast requirements)
Lithuania	[4.4.] LST 1005384.0001 '1 520 mm Railways With Passenger Train Speeds of Up to 160 km per Hour (hr)' [4.5.] LST 1005384.0002 'Track Structure of 1 520 mm Gauge Railways with Passenger Train Speeds of Up to 160 km/h' [4.16.] 'Instructions on Railway and Highway Roadbed Design' SN 449-72'
Poland	Parameter not standardised
Russia	[6.5.] Order No 41 of the Railways Ministry dated 12.11.2001 'Standard Speed Limits for Rolling Stock on the 1 520 (1 524)-mm Gauge Railway Tracks of Federal Railway Transportation'
Slovakia	Parameter not standardised
Ukraine	[8.9.] TsP-0117, Rules for Calculating Railway Track Strength and Stability section 3.2
Estonia	Parameter not standardised

Conclusion: The requirements for this parameter are different in different countries. This parameter will require additional study for development of uniform specifications for 1 520 mm gauge system.

## 5.5 STRUCTURES RESISTANCE TO TRAFFIC LOADS

### 5.5.1 Resistance of bridges to traffic loads

The requirements for this parameter are identical in all states except Poland and Slovakia.

Belarus, Latvia, Lithuania<sup>3</sup>, Russia, Ukraine<sup>4</sup> and Estonia: man-made structures (bridges, viaducts, etc.) are designed for load class S-14 (category 1 load bearing), in accordance with [1.5.] SNiP 2.05.03-84 'Bridges and Tubes'.

Bridges are designed for S14 loads (equivalent to SK) (axle load of 35 t, longitudinal load of 14 t/m) and N8 (equivalent to eight times N1) (axle load of 28 t, longitudinal load of 8 t/m) if there are no defects limiting speed.

The method of calculating equivalent loads on load bearing constructions of railway bridges under the N8 designation is based on two cancelled documents:

- [3.5.] SN 200-62 'Specifications for the Design of Railway, Highway, and Urban Bridges and Tubes';
- [1.8.] SNiP II-D.7-62 'Bridges and Tubes. Design Rules'

These documents have been replaced by [1.5.] SNiP 2.05.03-84 'Bridges and Tubes'.

As the N8 load scheme is also determinative in the production of bridge elements and materials, the notion of 'N8 load requirements' is still used for parts and materials used to repair bridges built before 1984.

---

<sup>3</sup> Lithuania uses both EN 1991-2:2003 '*Eurocode 1: Action on structures – Part 2. Traffic loads on bridges*' (the 71st loading model) and national instructions based on [1.5.] SNiP 2.05.03-84 'Bridges and Tubes'.

<sup>4</sup> In Ukraine, according to DBN V 2.3-14:2006 Bridges and Tubes, the baseline temporary loading from rolling stock is the SK load, analogous to the baseline load in [1.5.] SNiP 2.05.03-84 'Bridges and Tubes. For permanent bridges K=14; for temporary and wooden K=10.

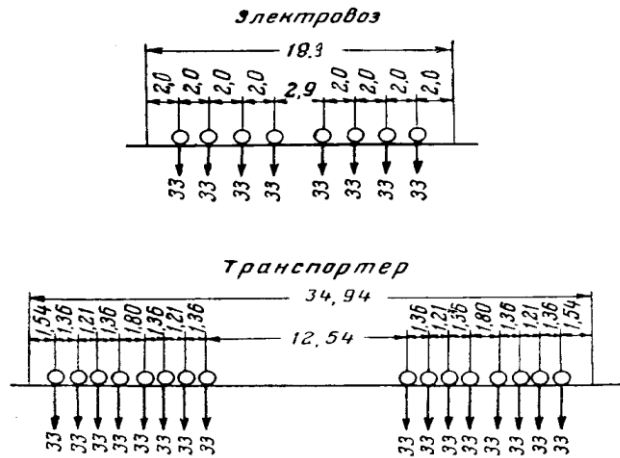

### S14 loading

[Top: diesel locomotive; Bottom: transporter]

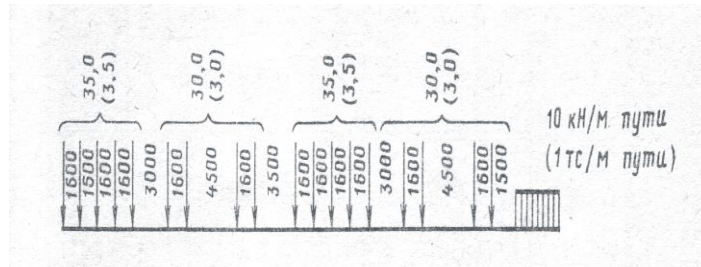

### N1 loading

[Top: 10 kN/m of track (1 ts/m of track)]

Latvia: on Category II and III lines, all structures should ensure passage of trains without speed restrictions.

Poland: maximum axle load is 25.0 t/axle, 8 t/m

Slovakia: only one category: 24.5 t/axle, 9 t/m

Conformity assessment method: calculation, experimental.

These requirements are approved in the following documents:

Belarus	[1.5.] SNiP 2.05.03-84 'Bridges and Tubes', section 2.11
Latvia	[3.5.] SN 200-62 'Specifications for the Design of Railway, Highway, and Urban Bridges and Tubes'
Lithuania	[4.2.] 'Instructions on Maintenance of Man-made Structures 147/K' EN1991-2:2003 Eurocode-1 actions on structure, part 2 traffic loads on bridges

Poland	[5.1.] Directive of the Minister of Transportation and the Maritime Economy dated 10.09.1998 (Legislative Journal No 151, p. 987 § 48)
Russia	[1.30.] Guidelines for Determining the Load-Bearing Capacity of the Metal Spans of Railway Bridges, Annexes 1 and 25. [1.5.] SNiP 2.05.03-84 'Bridges and Tubes' (s. 2.11; Annex 5);
Slovakia	[7.2.] Regulations on the Slovakian Railway PTE [7.1.] Slovakian Railway PTE
Ukraine	[8.4.] SK DBN V.2.3 -14:2006 Bridges and Tubes
Estonia	[9.7.] EVS 2007 for Bridges and Tubes [1.5.] SNiP 2.05.03-84 'Bridges and Tubes', section 2.11 (information document)

Conclusion: The requirements for this parameter are the same in all states except Poland and Slovakia. These documents and requirements may be taken as the basis when developing uniform specifications for 1 520 mm gauge system.

### 5.5.2 Equivalent vertical loading for earthworks and earth pressure effects

The requirements for this parameter are different in different countries.

Belarus, Latvia, Russia and Ukraine: the railway trackbed is designed and intended for axle loads of a 4-axle freight car: 294 kN (30 t/s).

Poland: 120 MPa.

Slovakia: 24.5 t per axle.

Estonia: 25.0 t per axle.

Conformity assessment method: calculation.

These requirements are approved in the following documents:

Belarus	[2.3.] SNB 3.03.01-98 '1 520 mm Railways', section 4.8
Latvia	Determined by the individual project. The Infrastructure Manager uses the following documents for information purposes: [3.12.] SP 32-104-98 'Designing the Roadbed of 1 520 mm Gauge Railways', Annex Г, [6.3.] STN Ts-01-95 '1 520 mm Gauge Railways', section 5.1, [1.6.] SNiP 32-01-95 '1 520 mm Gauge Railways' section 4.8.
Lithuania	No standards cover loads on earthworks. There are no precedents for

	new construction to date.
Poland	[5.1.] Directive of the Minister of Transportation and the Maritime Economy dated 10.09.1998 (Legislative Journal No 151, p. 987, §16)
Russia	[6.3.] STN Ts-01-95 '1 520 mm Gauge Railways' section 5.1
Slovakia	[7.2.] Regulations on the Slovakian Railway PTE [7.1.] Slovakian Railway PTE
Ukraine	[8.6.] DBN V.2.3.-19:2008 section 4.1
Estonia	

Conclusion: The requirements for this parameter are different in different countries and are not standardised in all countries. These documents and requirements may be taken as a basis when developing uniform specifications for the 1 520 mm gauge system.

### 5.5.3 Resistance of structures over or adjacent to tracks

This parameter refers solely to the aerodynamic effects at speeds above 80 km/h.

There are no uniform requirements for this parameter at present.

Poland has minimum distance requirements.

Conformity assessment method: calculation.

These requirements are approved in the following documents:

Belarus	Not standardised.
Latvia	Not standardised.
Lithuania	Not standardised.
Poland	[5.1.] Directive of the Minister of Transportation and the Maritime Economy dated 10.09.1998 (Legislative Journal No 151, p. 987, §94)
Russia	Not standardised. This parameter is being studied and may be standardised for the development of high-speed railways.
Slovakia	Not standardised.
Ukraine	Not standardised.
Estonia	Not standardised.

Conclusion: The requirements for this parameter are different in different countries and are not standardised in all states. This parameter will require additional study for development of a uniform specification for 1 520 mm gauge railways.



## 5.6 TRACK GEOMETRICAL QUALITY AND DEFECTS LIMITS ON ISOLATED SECTIONS

### 5.6.1 Determination of immediate action, intervention, and alert limits

Requirements for this parameter exist in all states. However, deviations from nominal values and determination of the respective actions are determined differently in different states.

All states require systematic checks on the following parameters:

1. Gauge variations
2. Level, twisting and depression
3. Deviations in layout
4. Conformity of cant change rate and curve
5. Actual maximum cant
6. Reverse cant in crossing and switching curves
7. Cant change rate in curves
8. Gauge rate of change

The nature of the action is established depending on the results of measurement.

Track status is appraised using a five-step system. Each step is given a point score (depending on the parameter), category IV or V require immediate action, categories I, II and III are rectified according to scheduled maintenance works.

These parameters are regulated for 1 520 mm gauge railways by the documents below.

These requirements are approved in the following documents:

Belarus	[2.2.] Enterprise Standards document (STP) 09150.56.010-2005 'Routine Railway Track Maintenance. Technical Requirements and Work Management', section 5.2.4
Latvia	[3.6.] Infrastructure Manager Technical Instructions No CEJ-7/185 dated 28.07.1998
Lithuania	[4.1.] 'Instructions on Routine Railway Track Maintenance K/111' [4.3.] 'Instructions on the Interpretation of Rail Spotter Readings and

	Track Evaluation, K/080'
Poland	[5.14.] Technical Regulations for Railway Infrastructure Managers
Russia	[6.4.] Instructions on the Routine Maintenance of Railway Tracks, TsP-774, section 2.2.2
Slovakia	[7.2.] Regulations on the Slovakian Railway PTE [7.1.] Slovakian Railway PTE
Ukraine	[8.7.] TsP-0020 Technical Instructions on Assessment of Track Geometry Based on Rail Spotter Readings and Ensuring Train Traffic Safety
Estonia	[9.5.] Estonian Railways PTE, section 27 Infrastructure Rules of Action, section 28 (reference to [6.4.] Instructions on the Routine Maintenance of Railway Tracks, TsP-774, section 2.2.2)

Conclusion: The requirements for these parameters are regulated in all states by standard limits and deviations from nominal values and the respective actions required are determined differently in different states. These documents and requirements may be taken as a basis when developing uniform specifications for the 1 520 mm gauge system.

### 5.6.2 Immediate action limit for track twist

Requirements for this parameter exist in all states and are appraised on the basis of speed limits, while the limits requiring differing degrees of action are not always the same.

Belarus, Latvia, Lithuania, Russia, Ukraine and Estonia: the following table provides immediate action limits for track twisting.

<b>Deviation from gradual curve break (twisting), mm</b>	<b>Speed of passenger/freight trains, km/h</b>
Up to 16	Not more than 140/90
16 to 20	Not more than 120/80
20 to 25	Not more than 60
25 to 30 incl.	Not more than 40
Over 30	Not more than 15

Over 50	Track closes
---------	--------------

Poland: track twisting limit is – 6 ‰ depending on speed.

Conformity assessment method: geometric measurement.

These requirements are approved in the following documents:

Belarus	[2.2.] Enterprise Standards document (STP) 09150.56.010-2005 'Routine Railway Track Maintenance. Technical Requirements and Work Management'
Latvia	[3.6.] Infrastructure Manager Technical Instructions No CEJ-7/185 dated 28.07.1998
Lithuania	[4.3.] 'Instructions on the Interpretation of Rail Spotter Readings and Track Evaluation, K/080'
Poland	[5.14.] Technical Regulations for Railway Infrastructure Managers
Russia	[6.4.] Instructions on the Routine Maintenance of Railway Tracks, TsP-774, section 2.2.2
Slovakia	No rail spotter car, no instructions.
Ukraine	[8.7.] TsP-0020 Technical Instructions on Assessment of Track Geometry Based on Rail Spotter Readings and Ensuring Train Traffic Safety
Estonia	Track maintenance instructions

Conclusion: These requirements are standardised in all states, but there may be differences. These documents and requirements may be taken as a basis when developing uniform specifications for the 1 520 mm gauge system.

### 5.6.3 The immediate action limit for variation of track gauge

Requirements for this parameter are identical in all states except Poland.

Belarus, Latvia, Lithuania, Russia, Slovakia, Ukraine and Estonia: More than 1 548 mm or less than 1 512 mm – track closes.

Interim values and the respective speed restrictions for straight and curved sections are given below on the basis of regulatory documents.

These values are the maximum limits. There are also interim values requiring speed restrictions. The interim values are not the same in all states.

Poland: permitted variations in gauge depending on speed are as follows:

Speed	Permitted variation	
120 km/h	+9	-7
100 km/h	+10	-7
80 km/h	+10	-8
70 km/h	+12	-8
60 km/h	+15	-8
50 km/h	+17	-8
40 km/h	+20	-9
30 km/h	+25	-9
20 km/h	+25	-10

Polish maximum limits: more than 1 545 mm or less than 1 510 mm, track closes.

Conformity assessment method: geometric measurement.

These requirements are approved in the following documents:

Belarus	[2.2.] Enterprise Standards document (STP) 09150.56.010-2005 'Routine Railway Track Maintenance. Technical Requirements and Work Management', section 5.2.4
Latvia	[3.3.] 'PTE of the Latvian Railway', section 30 [3.4.] 'Instructions on Routine Track Maintenance'
Lithuania	[4.3.] 'Instructions on the Interpretation of Rail Spotter Readings and Track Evaluation, K/080' [4.1.] 'Instructions on Routine Railway Track Maintenance K/111'
Poland	[5.9.] Id 19 Specifications for Superstructure Maintenance on 1 520 and 1 524-mm Gauge Railway Lines
Russia	[6.1.] PTE for Railways of the Russian Federation [6.4.] Instructions on the Routine Maintenance of Railway Tracks, TsP-774, section 2.2.2
Slovakia	[7.2.] Regulations on the Slovakian Railway PTE [7.1.] Slovakian Railway PTE
Ukraine	[8.7.] TsP-0020 Technical Instructions on Assessment of Track Geometry Based on Rail Spotter Readings and Ensuring Train Traffic Safety
Estonia	[9.5.] Estonian Railways PTE

Conclusion: The requirements for this parameter are standardised in all states, but may have differences. These documents and requirements may be taken as a basis when developing uniform specifications for the 1 520 mm gauge system.

#### 5.6.4 Immediate action limit for cant

Requirements for this parameter exist in all states and are assessed on the basis of speed limits, while the limits requiring differing degrees of action are not always the same.

The requirements for this parameter are identical in all states except Poland and Slovakia.

Belarus, Latvia, Lithuania, Russia, Ukraine and Estonia: the following table shows immediate action limits for track depression.

Variation in level from normal cant (depression), mm	Speed of passenger/freight trains, km/h
Up to 20	Not more than 140/90
20 to 25	Not more than 120/80
25 to 30	Not more than 60
30 to 35	Not more than 40
Over 35	Not more than 15
Over 45	Track closes

Poland and Slovakia: not more than 150 mm; permitted variation – up to 25 mm depending on speed.

Conformity assessment method: geometric measurement.

These requirements are approved in the following documents:

Belarus	[2.2.] Enterprise Standards document (STP) 09150.56.010-2005 'Routine Railway Track Maintenance. Technical Requirements and Work Management', section 5.2.10, section 5.2.11
Latvia	[3.6.] Infrastructure Manager Technical Instructions No CEJ-7/185

	dated 28.07.1998
Lithuania	[4.3.] 'Instructions on the Interpretation of Rail Spotter Readings and Track Evaluation, K/080'
Poland	[5.14.] Technical Regulations for Railway Infrastructure Managers
Russia	[6.1.] PTE for Railways of the Russian Federation [6.4.] Instructions on the Routine Maintenance of Railway Tracks, TsP-774, section 2.2.2
Slovakia	[7.2.] Regulations on the Slovakian Railway PTE [7.1.] Slovakian Railway PTE
Ukraine	[8.2.] TsP-0138 Instructions on the Installation and Maintenance of Ukrainian Railway Tracks, section 2.1.4
Estonia	Instructions on track maintenance, Infrastructure Manager's documents

Conclusion: The requirements for this parameter are standardised in all states, but there may be differences. These documents and requirements may be taken as a basis when developing uniform specifications for the 1 520 mm gauge system.

## 5.7 PLATFORMS

### 5.7.1 Usable length of platforms

The requirements for this parameter are different in different countries.

Belarus and Ukraine:

For passenger trains at stations – 500 m.

For local train services – 300 m.

Latvia: not less than 400 m for stations where long distance trains stop; not less than 80 m for other stations and stops.

Lithuania: must match train length

Poland:

400 m – for 16-car trains

300 m – for 12-car trains

200 m – for 8-car trains

Russia: Passenger platform length must correspond to the longest passenger train length expected to be in operation after five years. New stations should have extended platforms of 650 – 850 m, platforms for local services only – up to 500 m. For certain routes, extended platforms of up to 1 000 m fitted with special devices for passenger and baggage movement are permitted by instruction of the Russian Federation Railways Ministry.

Slovakia: no passenger stations on 1 520 mm gauge track.

Estonia: depends on length and type of train (local, international); minimum 30 m, maximum: in Tallinn, 22 cars + locomotive (approximately 600 m).

Conformity assessment method: geometric measurement.

These requirements are approved in the following documents:

Belarus	According to design [2.6.] Standards for the Technological Design of Suburban Stations (VNTP No 78 of the MPS) [2.7.] VSN-01-91 'Railway Stations for Through Service Passengers'
Latvia	[3.1.] LVS 484-2008 'Railway Applications. Passenger Platforms on 1 520 mm Gauge Railway Lines' [1.34.] AGC
Lithuania	[4.6.] 'Railway Station Design Rules, 15/LG'
Poland	[5.1.] Directive of the Minister of Transportation and the Maritime Economy dated 10.09.1998 (Legislative Journal No 151, p. 987, §98)
Russia	[6.3.] STN Ts-01-95 '1 520 mm Gauge Railways', section 13.8
Slovakia	Not standardised. No passenger stations on 1 520 mm gauge lines.
Ukraine	[1.1.] Construction Norms and Regulations (SNiP) II-39-76 '1 520 mm Gauge Railways', Part II, chapter 39, section 10.8
Estonia	[9.5.] Estonian Railways PTE, 2006 amendments [9.8.] EVS 867:2003/2006 standard, cited in PTE

Comments:

- Station class (issue for OSJD Committee).
- Main parameter – train length.

Conclusion: The requirements for this parameter are different in different countries and are not standardised in all states. This parameter will require additional study for development of a uniform specification for 1 520 mm gauge railways.

## 5.7.2 Width and edge of platforms

The requirements for this parameter are different in different countries.

Belarus and Ukraine: 3 m.

Latvia: minimum 2 500 mm

Lithuania: Category I and III lines – 4 m; other lines – 3 m.

Poland: Width of passenger platforms is established depending on the facilities and devices to be installed on them.

Russia:

Width of passenger platforms depends on the intensity and nature of passenger flows (long-distance, local, suburban), speed of passenger trains, number and location of exits from platforms and platform facilities (stairs, pavilions, etc.).

The width of the main side platform should be no less than 6 m, and for refurbished stations in difficult conditions not less than 5 m where there are adjoining buildings and not less than 4 m for the remaining length.

The width of main side passenger platforms outside passenger buildings in stations with a capacity of 200 persons may be reduced to 3 m.

The width of platforms between lines on category III and IV lines should be not less than 4 m.

Slovakia: no passenger stations on 1 520 mm gauge lines.

Estonia: 4 m between lines and 3 m or more on the outside of lines.

Conformity assessment method: geometric measurement.

These requirements are approved in the following documents:

Belarus	According to design [2.6.] Standards for the Technological Design of Suburban Stations (VNTP No 78 of the MPS) [2.7.] VSN-01-91 'Railway Stations for Through Service Passengers'
Latvia	[3.1.] LVS 484-2008 'Railway Applications. Passenger Platforms on 1 520 mm Gauge Railway Lines'
Lithuania	[4.6.] 'Railway Station Design Rules, 15/LG'



Poland	[5.1.] Directive of the Minister of Transportation and the Maritime Economy dated 10.09.1998 (Legislative Journal No 151, p. 987, section 98)
Russia	[6.3.] STN Ts-01-95 '1 520 mm Gauge Railways', section 13.9
Slovakia	Not standardised. No passenger stations on 1 520 mm passenger lines.
Ukraine	[1.1.] Construction Norms and Regulations (SNiP) II-39-76 '1 520 mm Gauge Railways', part II, chapter 39, section 10.9
Estonia	[9.6.] EVS 867:2003/A1:2007, , section 19 [9.4.] RTL 2001 129, 1870 Manual for the Application of Gauges paragraph 19, minimum gauge requirements [1.54] Persons with Reduced Mobility TSI including 2006 amendments.

Conclusion: The requirements for this parameter are different in different countries and are not standardised in all states. This parameter will require additional study for development of a uniform specification for 1 520 mm gauge railways.

### 5.7.3 Height of Platforms (high and low)

The requirements for this parameter are different in different countries.

Belarus, Russia, and Ukraine: Passenger and freight platforms on lines with mixed passenger and freight trains shall be the following heights from the rails:

1 100 mm for high platforms,

200 mm for low platforms.

Tolerance +20 mm -50 mm.

High freight and passenger platforms are permitted in certain cases to be higher than 1 100 mm from the rail height.

Latvia, Lithuania, Poland and Estonia: according to 4.1.2.18.1 of the Persons with Reduced Mobility TSI, new platforms are permitted at 550 mm and 760 mm (- 35 mm + 0 mm) from the rails.

Latvia, Lithuania and Estonia: in accordance with section 7.4.1.1 of the Persons with Reduced Mobility TSI, new platforms are permitted at 200 mm and 1 100 mm (+20 mm -50 mm) from the rails.

Latvia: the new standard sets the following heights from rails: 200 mm, 550 mm; 1 100 mm has been removed. The standard was produced with consideration for the Persons with Reduced Mobility TSI, EVS and the Finnish standard. Amendments to the PTE are being prepared that will add a reference to the standard, after which it will be mandatory.

Lithuania: There is one 1 100 mm platform for tourist purposes.

Poland: 300 mm for baggage platforms.

Slovakia: no passenger stations on 1 520 mm gauge lines.

Conformity assessment method: geometric measurement.

These requirements are approved in the following documents:

Belarus	[2.1.] PTE of the Belarusian Railway, section 5.3. [1.12.] GOST 9238-83 '1 520 (1 524) mm Gauge Railway Minimum Gauges for Structures and Rolling Stock', section 2.1.3
Latvia	[1.54] Persons with Reduced Mobility TSI [3.1.] LVS 484-2008 'Railway Applications. Passenger Platforms on 1 520 mm Gauge Railway Lines' [3.3.] 'PTE of the Latvian Railway'
Lithuania	[1.54] Persons with Reduced Mobility TSI [4.7.] 'Lithuanian Railway '
Poland	[1.54] Persons of Reduced Mobility TSI [5.1.] Directive of the Minister of Transportation and the Maritime Economy dated 10.09.1998 (Legislative Journal No 151, p. 987, §98)
Russia	[6.1.] PTE for Railways of the Russian Federation section 5.3.
Slovakia	Not standardised. No passenger stations on 1 520 mm gauge lines.
Ukraine	[8.1.] Ukrainian Railway PTE, section 5.3.
Estonia	[1.54] Persons with Reduced Mobility TSI [9.5.] Estonian Railways PTE, section 53

Conclusion: The requirements for this parameter are different in different countries and are not standardised in all states. This parameter will require additional study for development of a uniform specification for 1 520 mm gauge railways.

#### 5.7.4 Offset of platforms

This parameter is the same in all states except Slovakia.

Belarus, Latvia, Lithuania, Poland, Russia, Ukraine and Estonia:

- 1 920 mm – for high platforms (platforms over 200 mm)
- 1 745 mm – for low platforms (200 mm platforms) (except Poland, where new 200 mm platforms are forbidden)
- Tolerance +30 mm -25 mm

Slovakia: no passenger stations on 1 520 mm gauge lines.

Conformity assessment method: geometric measurement.

These requirements are approved in the following documents:

Belarus	[2.1.] PTE of the Belarusian Railway, section 5.3. [1.12.] GOST 9238-83 '1 520 (1 524) mm Gauge Railway Minimum Gauges for Structures and Rolling Stock', section 2.1.3
Latvia	[1.54] Persons with Reduced Mobility TSI [3.1.] LVS 484-2008 'Railway Applications. Passenger Platforms on 1 520 mm Gauge Railway Lines' [3.3.] 'PTE of the Latvian Railway'
Lithuania	[1.54] Persons with Reduced Mobility TSI [4.7.] 'Lithuanian Railway '
Poland	[1.54] Persons with Reduced Mobility TSI [5.1.] Directive of the Minister of Transportation and the Maritime Economy dated 10.09.1998 (Legislative Journal No 151, p. 987, §98)
Russia	[6.1.] PTE for Railways of the Russian Federation section 5.3
Slovakia	Not standardised. No passenger stations on 1 520 mm gauge lines.
Ukraine	[8.1.] Ukrainian Railway PTE, section 5.3.
Estonia	[1.54] Persons with Reduced Mobility TSI [9.5.] Estonian Railways PTE, paragraph 53, no information on low platforms other than reference to use of standard.

Conclusion: The requirements for this parameter are the same in all states except Slovakia. These documents and requirements may be taken as a basis when developing uniform specifications for the 1 520 mm gauge system.

### 5.7.5 Characteristics of platforms linked to the access of people with reduced mobility

This parameter is governed by the national law of each state. There are no uniform requirements for this parameter.

Latvia, Lithuania, Poland and Estonia: in accordance with the Persons with Reduced Mobility TSI.

Belarus, Russia and Ukraine: rules apply for access to station buildings, platforms, etc. for persons with limited mobility: ramps, lifts, etc.

Slovakia: no passenger stations on 1 520 mm gauge lines.

Conformity assessment method: visual, geometric measurement.

These requirements are approved in the following documents:

Belarus	[6.18.] Technical Regulations (TR) for Outfitting Railway Terminals [6.19.] Long-Distance Passenger Railway Terminal Design Standards
Latvia	[1.54] Persons with Reduced Mobility TSI [3.1.] LVS 484-2008 'Railway Applications. Passenger Platforms on 1 520 mm Gauge Railway Lines'. The standard is harmonised with [1.54.] Persons with Reduced Mobility TSI
Lithuania	[1.54] Persons with Reduced Mobility TSI No special documents. [4.11.] STR 2.03.01.2001, 'Facilities and Grounds. Requirements Regarding Persons With Reduced Mobility'
Poland	[1.54] Persons with Reduced Mobility TSI [5.1.] Directive of the Minister of Transportation and the Maritime Economy dated 10.09.1998 (Legislative Journal No 151, p. 987, §98)
Russia	[6.18.] Technical Regulations (TR) for Outfitting Railway Terminals [6.19.] Long-Distance Passenger Railway Terminal Design Standards
Slovakia	No passenger stations on 1 520 mm gauge lines.
Ukraine	General national and department design and construction rules
Estonia	[1.54] Persons with Reduced Mobility TSI [9.8.] EVS 867:2003/2006 standard

Conclusion: The requirements for this parameter are different in different countries and are not standardised in all countries. This parameter will require additional study for development of a uniform specification for 1 520 mm gauge railways.

### 5.7.6 Width and edge of platforms (end of platforms)

There are no uniform requirements for this parameter.

Belarus, Russia: in accordance with the indicated documents.

Latvia, Lithuania, Poland and Estonia: in accordance with the [1.54.] Persons with Reduced Mobility TSI.

Latvia: Safety zone of at least 800 mm (standard harmonised with the Persons with Reduced Mobility TSI).

Slovakia: no passenger stations on 1 520 mm gauge lines.

Conformity assessment method: visual, geometric measurement.

These requirements are approved in the following documents:

Belarus	[6.18.] Technical Regulations (TR) for Outfitting Railway Terminals [6.19.] Long-Distance Passenger Railway Terminal Design Standards
Latvia	[3.1.] LVS 484-2008 'Railway Applications. Passenger Platforms on 1 520 mm Gauge Railway Lines' [1.54] Persons with Reduced Mobility TSI
Lithuania	[1.54] Persons with Reduced Mobility TSI
Poland	[5.1.] Directive of the Minister of Transportation and the Maritime Economy dated 10.09.1998 (Legislative Journal No 151, p. 987, §98) [1.54] Persons with Reduced Mobility TSI
Russia	[6.18.] Technical Regulations (TR) for Outfitting Railway Terminals [6.19.] Long-Distance Passenger Railway Terminal Design Standards
Slovakia	No passenger stations on 1 520 mm passenger lines.
Ukraine	Not standardised
Estonia	[9.8] EVS 867:2003/2006 standard [1.54.] Persons with Reduced Mobility TSI

Conclusion: The requirements for this parameter are different in different countries and are not standardised. This parameter will require additional study for development of a uniform specification for 1 520 mm gauge railways.

## **5.8 HEALTH, SAFETY AND ENVIRONMENT**

### **5.8.1 Maximum pressure variation in tunnels**

This parameter is not standardised for 1 520 mm gauge system.

Lithuania: the only tunnel in the country is an architectural monument (TSI do not fully apply).

Belarus, Latvia, Poland (1 520 lines), Slovakia (1 520 lines), Estonia: no tunnels.

Conclusion: This parameter is not standardised for 1 520 mm gauge system. This parameter will require additional study for development of a uniform specification for 1 520 mm gauge railways.

### **5.8.2 Piston effects in underground stations**

This parameter is not standardised in 1 520 mm gauge system.

Belarus, Latvia, Lithuania, Poland (1 520 mm lines), Slovakia (1 520 mm lines), Russia, Ukraine, Estonia: no underground stations.

Conclusion: This parameter is not standardised for the 1 520 mm gauge system. This parameter will require further study in development of uniform specifications for the 1 520 mm system.

### **5.8.3 Noise and vibration limits and mitigation measures**

The requirements for this parameter are different in different countries.

Belarus, Russia and Ukraine: sound level requirements are set individually in each case. In practice, requirements apply to sound levels produced by machinery and set back zones are used.

Russia: sound levels in tunnels produced by ventilation equipment must not exceed the values indicated in table 5 ([1.7.] SNiP 32-04-97 'Railway and Highway Tunnels'), and in technological, ancillary and service premises, the values in [1.13.] GOST 12.1.003-83 'Noise. General Safety Requirements'.

Table 5 [[1.7.] SNiP 32-04-97 'Railway and Highway Tunnels']  
Sound levels produced by ventilation equipment in tunnels

Geometric frequencies, octave bandwidths, Hz	63	125	250	500	1 000	2 000	4 000	8 000
Sound pressure level, dB	97	88	83	76	72	62	54	47

Latvia, Lithuania, Poland, Slovakia and Estonia: railway transportation as a whole must conform to requirements restricting sound levels in residential areas during the day and night ([1.49.] Directive 2001/49/EC (Noise Level Assessment and Monitoring)).

Poland: vibration levels in accordance with [5.11.] PN 85/B-02170 – Assessment of the Harmfulness of Vibrations Transmitted to Buildings by the Roadbed.

Environmental noise levels in accordance with [5.4.] Directive of the Minister of the Environment dated 14 June 2007 on permissible noise levels in the environment (Legislative Gazette 2007 No 120, p. 826),

Conformity assessment method: instrumental.

These requirements are approved in the following documents:

Belarus	[1.13.] GOST 12.1.003-83 'Noise. General Safety Requirements', section 2.3.
Latvia	No standards for railway infrastructure. <sup>5</sup>
Lithuania	No standards for railway infrastructure. <sup>6</sup>
Poland	[5.4.] Directive of the Minister of the Environment dated 14 June 2007 on permissible noise levels in the environment (Legislative Gazette 2007 No 120, art. 826). [5.5.] Directive of the Minister of the Environment dated 2 October 2007 on requirements regarding the performance of substance or power level measurements in the environment by a highway, railway line, trolley line, airport, or port manager (Legislative Gazette 2007 No 192, article 1392), [5.11.] PN 85/B-02170 – Assessment of the Harmfulness of Vibrations Transmitted to Buildings by the Roadbed [1.55.] Rolling Stock Noise Level TSI

<sup>5</sup> The noise TSI makes special provision for Latvia, Lithuania and Estonia, according to which the requirements for permitted noise levels do not apply in these states until the next revision of the TSI.

<sup>6</sup> See footnote 5.

Russia	[1.7.] SNiP 32-04-97 'Railway and Highway Tunnels' [1.13.] GOST 12.1.003-83 'Noise. General Safety Requirements'
Slovakia	[7.3.] Regulations of the Slovak Republic on Noise and Vibration Protection [1.55.] Rolling Stock Noise Level TSI
Ukraine	[1.29.] BPC No. 4137-86 Labour Hygiene Classification
Estonia	No standards for railway infrastructure. <sup>7</sup>

Conclusion: The requirements for this parameter are different in different countries and are not standardised in all states. This parameter will require additional study for development of a uniform specification for 1 520 mm gauge system.

#### 5.8.4 Protection against electric shock

In all states, a complex of measures applies for electrical protection, including

1. Earthing traction substations; contact system catenary support; feeder and negative boost line catenary support; relay boxes, contact system and traffic light insulation in tunnels; bridge and crossing and other infrastructure construction.
2. Distance protection.
3. Fencing.
4. Insulation.

Conformity assessment method: instrumental.

These requirements are approved in the following documents:

Belarus	[1.10.] GOST 12.1.019-79 'Electrical Safety. General Requirements and Types of Protection'
Latvia	[1.31.] 'Automation and Remote Control Devices on Railway Vehicles, Departmental Process Design Standards (VNTP)/MPS-85' [3.3.] 'PTE of the Latvian Railway', sections 161, 190, 191
Lithuania	[4.9.] 'Rules on the Technological Design of Railway Signalling Devices', 25/AA' [4.10.] 'Instructions on Earthing Power Supply Devices On Electrified Railways'

<sup>7</sup> See footnote 5.



Poland	<p>[5.6.] Directive of the Minister of the Economy dated 17 September 1999 on labour safety and hygiene for electric power equipment and wiring (Legislative Gazette 1999 No 80, p. 912, section 55)</p> <p>[5.7.] 'Instructions on Work Place Safety and Hygiene for Railway Electric Power Equipment. Work on or near Catenary Equipment or Power Lines, Excluding the Traction Demands on EBH-1a Overhead Conductor Structures'</p> <p>[5.10.] PN-EN 50122-1:2002 Railway Applications. Permanent Installations. Part 1: Protection Equipment Relating to Safety and Earthing</p>
Russia	<p>[6.6] Instructions No L-1318u of the Railways Ministry of Russia dated 18 November 1998</p> <p>[6.13] Instructions on the Maintenance of Manmade Structures. No TsP-628 dated 28 December 1998 (13.9-13.10)</p> <p>[6.14.] Instructions on the Earthing of Power Supply Devices on Electrified Railways, No TsE-191</p>
Slovakia	<p>[7.2.] Regulations on the Slovakian Railway PTE</p> <p>[7.1.] Slovakian Railway PTE</p>
Ukraine	[8.8.] DNAOP 1.1.10-1.07-01. ISBN 966-7097-40-4
Estonia	<p>[9.5.] Estonian Railways PTE, reference to electrical safety.</p> <p>[9.9.] 1985 Estonenergo Rules on Construction of Electrical Facilities</p> <p>[9.10.] Rules on Construction of Contact Systems and Electrified Line Substations 9-1/23 30.09.2002 EVR</p>

Conclusion: The requirements for this parameter include a complex of measures, of which detailed requirements may differ in different countries. This parameter will require additional study for development of a uniform specification for 1 520 mm gauge system.

### 5.8.5 Safety in railway tunnels

There are no uniform requirements for this parameter.

Belarus, Latvia, Poland (1 520 lines), Slovakia (1 520 lines) and Estonia: no railway tunnels.

Lithuania: the only tunnel in the country is an architectural monument (during its recent reconstruction, the TSI tunnel safety requirements were not fully applied).

Latvia, Lithuania, Poland, Slovakia and Estonia: in the event new tunnels are built, [1.56.] Safety in Rail Tunnels TSI will apply, according to which requirements apply to the following parameters:

- Switches and crossings inside tunnels,
- Preventing unauthorised access,
- Fire safety requirements for structures,
- Fire safety requirements for construction materials,
- Fire detection systems,
- Emergency exit, evacuation and rescue equipment,
- Emergency exit routes,
- Emergency lighting for exit routes,
- Emergency exit signs,
- Emergence communications apparatus,
- Rescue service access,
- Rescue areas near tunnels,
- Water supplies

Russia: according to the rules on construction of new tunnels and reconstruction of old ones [1.7.] SNiP 32-04-97 'Railway and Highway Tunnels':

- Tunnels must have cameras and niches.
- Tunnels more than 1 500 m in length or the entrances thereto must have special rooms with sanitary and personal equipment for the requirements of operating services and guards.
- Railway tunnels more than 3 000 m must have additional emergency exits fitted with hermetic locks and local ventilation.
- Tunnels must be protected from penetration by surface or ground waters, and have drainage systems as required.
- Drains must be fitted with barriers (siphons) to prevent leakage of burning petroleum products.
- Tunnels of more than 100 m in length with one-way traffic at speeds over 100 km/h should be built with a flared entrance.

- Tunnels must have ventilation systems with natural or artificial induction.
- Tunnels must have fire protection.
- Tunnels and service galleries must have fixed general and emergency lighting.

In addition to the above, according to the operating procedures ([6.13.] Instructions for the Maintenance of Manmade Structures. No TsP-628 dated 28 December 1998):

- Guards must install fire extinguishers in guarded tunnels.
- Guardrooms of bridges (tunnels) and bridge inspectors must have direct telephone lines to the nearest station or post, and for sections with central dispatchers, to the train dispatcher.
- Tunnels on the list approved by the line chief (usually more than 300 m in straights and more than 150 m on curved sections of track) are fitted with warning alarms and traffic lights.

Ukraine: railway tunnel safety is regulated by [1.3.] SNiP II-44-78 'Railway and Highway Tunnels', [1.2.] SNiP III-44-77 'Work Performance and Acceptance Rules. Railway and Hydraulic-Engineering Tunnels. Underground Railways'. Presumably any new projects will be governed by new rules or European standards.

Conformity assessment method: calculation, experimental, visual, instrumental.

These requirements are approved in the following documents:

Belarus	Not regulated
Latvia	[1.56.] Safety in Rail Tunnels TSI
Lithuania	[1.56.] Safety in Rail Tunnels TSI
Poland	[1.56.] Safety in Rail Tunnels TSI
Russia	[1.7.] SNiP 32-04-97 'Railway and Highway Tunnels', sections 3.8-3.16, 5.17, 7.18, 7.26-7.28, 7.33-7.38 and 7.40-7.41 [6.13.] Instructions on the Maintenance of Manmade Structures. No TsP-628 dated 28 December 1998 (sections 13.4, 13.5, 13.6, 13.11-13.14, 13.16)
Slovakia	[1.56.] Safety in Rail Tunnels TSI
Ukraine	[1.3.] SNiP II-44-78 'Railway and Highway Tunnels' [1.2.] SNiP III-44-77 'Work Performance and Acceptance Rules. Railway and Hydraulic-Engineering Tunnels. Underground Railways'.

Estonia	[1.56.] Safety in Rail Tunnels TSI
---------	------------------------------------

Conclusion: The requirements for this parameter are different in different countries and are not standardised in all states. This parameter will require additional study for development of a uniform specification for 1 520 mm gauge railways.

### 5.8.6 Effect of crosswinds

This parameter refers to means of protecting moving trains from crosswinds.

There are no uniform requirements for means of protecting moving trains from crosswinds.

A range of measures are used to protect infrastructure from climatic factors.

Belarus, Russia: sections of railway affected by annual strong winds (speeds over 15 m/s), black ice, and silting on non-agricultural land or land unsuited for cultivation, should be provided with wind breaking tree plantations. If strong gusts of wind are capable of threatening safe rail traffic, windbreaks may be planted on agricultural land.

In practice, since [1.1.] Construction Norms and Regulations (SNiP) II-39-76 '1 520 mm Gauge Railways' contained similar requirements, these requirements were also applied in Latvia, Lithuania, Ukraine and Estonia.

Ukraine: a range of measures are implemented to protect infrastructure from climatic factors, including special windbreak plantations.

Conformity assessment method: instrumental, calculation.

These requirements are approved in the following documents:

Belarus	[1.6.] SNiP 32-01-95 '1 520 mm Gauge Railways', sections 6, 6.5
Latvia	No regulations.
Lithuania	No regulations.
Poland	No regulations.
Russia	[1.6.] SNiP 32-01-95 '1 520 mm Gauge Railways', sections 6, 6.5
Slovakia	No regulations.
Ukraine	[8.6.] DBN V.2.3.-19:2008, section 8.12
Estonia	No regulations.

Conclusion: The requirements for this parameter are not regulated for 1 520 mm gauge system in all states. This parameter will require additional study for development of a uniform specification for 1 520 mm gauge system.

## **5.9 PROVISION FOR OPERATION**

### **5.9.1 Distance markers**

The requirements for this parameter are identical in all states except Poland.

Belarus, Latvia, Lithuania, Russia, Slovakia (1 520 lines), Ukraine and Estonia:

Signals and signs are placed on main lines. Distance posts are placed at switches and other track intersections. Signal signs are placed to the right side of traffic direction, track signs to the right with distances in kilometres, at least 3 100 mm from the axis of the outer track.

Marker posts and kilometre posts are placed:

- Marker posts: every 100 m;
- Kilometre posts: every 1 000 m;

Distance marking requirements include the following points that relate to technical servicing, but not to interoperability:

- Reference markers on curved sections of track,
- Markings at the beginning and end of transition curves, beginning and end of curve on rail web;
- Markings of curved switches axis;
- Markings of ribbons of continuous rail (ribbon No, welding train No, length, fixing temperature, date laid).

Poland: hectometre posts are placed as either white marker posts or signs each 100 m on the trackside or contact system supports, alternating on the right and left sides relative to main and open lines.

Conformity assessment method: visual, instrumental.

These requirements are approved in the following documents:

Belarus	[2.1.] PTE of the Belarusian Railway, section 3.33.
Latvia	[3.3.] 'PTE of the Latvian Railway' [1.32.] 30.07.1978. Order No. 27TsZ of the MPS USSR 'On the Design of Standard Permanent Reduce Speed Signs, Portable Signals, and Markers and Track Signs' [3.4.] 'Instructions on Routine Track Maintenance'
Lithuania	[4.1.] 'Instructions on Routine Railway Track Maintenance K/111'
Poland	[5.14.] Technical Regulations for Railway Infrastructure Managers
Russia	MPS Order No 9 of 03.07.1991 'On Construction of Standard Permanent Reduce Speed Disks, Mobile Signals, Markers and Track Signs'
Slovakia	[7.6.] TNZ 34 2605, 'Painting the Safety Designation Signs of Railway Signalling and Safety Devices'
Ukraine	[8.2] TsP-0138 Instructions on the Installation and Maintenance of Ukrainian Railway Tracks, p. 3.12
Estonia	[9.5.] Estonian Railways PTE, paragraph 47, Part 2 of PTE signal instructions.

Conclusion: The requirements for this parameter are identical in all states except Poland. These requirements and documents may be taken as the basis for developing uniform specifications for 1 520 mm gauge system (subject to minor differences in Poland).

## 5.10 FIXED INSTALLATIONS FOR SERVICING TRAINS

The requirements for fixed installations for servicing trains as part of the system of regulatory acts for 1 520 mm gauge system are not reflected in the Subsystem 'Infrastructure. Track and Track Facilities'.

Requirements for distance between track centres for (passenger) trains and neighbouring tracks are different in various countries.

Lithuania (according to [4.6.] 'Railway Station Design Rules, 15/LG') and Russia ([1.21.] Official Construction Standards (VSN) 56-78 Instructions on Designing Stations and Railway Junctions of the USSR):

Distance between track centres:

1. Passenger coach parking areas (except suburban):

- standard: alternating each track 5 300 mm and 7 500 mm;
- minimum: 4 500 mm.

2. Passenger coach parking areas, suburban:

- standard: 5 300 mm and after each 4-5 tracks 7 500 mm;
- minimum: 4 500 mm.

3. Passenger coach parking areas if bogies are used to supply cars with fuel and passenger service items:

- long-distance and local trains: alternating after each track 5 300 and 7 500 mm;
- suburban trains: 5 300 mm and after each 4-5 tracks 7 500 mm.

4. If water restocking points installed:

- standard: 5 300 mm;
- minimum: 4 800 mm.

Latvia: minimum distances between tracks are established in the technical requirements for infrastructure in the PTE.

Poland and Slovakia: Not standardised; 1 520 mm trains are not serviced; no installations.

Ukraine: minimum distances between tracks set by PTE.

Estonia: Not standardised; indirect indications that water supply and washing facilities should be installed; no specific requirements.

### 5.10.1 Toilet discharge

The requirements for this parameter are not standardised at state level. In each case, an individual approach is applied as agreed with the infrastructure manager and the railway undertaking.

Accumulation tanks must be emptied using standard couplings.

Belarus:

Vacuum apparatus PZh-2.5. Used to empty vacuum toilets in passenger coaches

Nominal capacity: 0.63 m<sup>3</sup>/min;

Receiver capacity: 0.150 m<sup>3</sup>;

Power rating: 5.5 kW

Russia: Komlok 3 couplings are used. Maximum evacuation pressure 0.08 MPa.

Ukraine:

- Sanitation tank vehicles used.
- Minimum distance between tracks for train servicing and neighbouring tracks is 3.5 - 5.0 m;
- Coupling – hose coupling Ø100 mm;
- Maximum evacuation pressure – 0.09 MPa.

Poland and Slovakia: no equipment of this type on 1 520 mm lines.

Conformity assessment method: inspection of technical fittings, comparison of geometrical dimensions and technical characteristics.

These requirements are approved in the following documents:

Belarus	[2.9.] TsMV-2 Instructions on Operating Procedure and Safe Servicing of the PZh-2.5 Vacuum System Design regulations
Latvia	Requirements not standardised
Lithuania	Requirements not standardised
Poland	Requirements not standardised
Russia	[1.35.] OSJD Leaflet O+R 563 'Solutions and Recommendations



	for the Standardisation of Sanitation Facilities in Passenger coaches', 2nd edition' [6.17.] ST.1.15.11.04-07, Public Health and Disease Control Safety Standard
Slovakia	No regulations.
Ukraine	Regulations under development
Estonia	Requirements not standardised. Indirectly referred to in [9.5.] Estonian Railways PTE, paragraph 48-49 for water supply and sewerage [9.11] PPPV 1996 [9.12] Instructions on Preparation of Freight Cars for Carriage [9.13] V-010 1998 EVR

Conclusion: The requirements for this parameter are different in different countries and are not standardised in all states. This parameter will require additional study for development of a uniform specification for 1 520 mm gauge system.

### 5.10.2 Train external cleaning facilities

The requirements for this parameter are different in different countries and are not standardised in all states. In certain cases an individual approach is taken by agreement between the infrastructure manager and the railway undertaking.

Belarus, Russia, and Ukraine: the main applicable requirements are provided in the following table.

	<b>Belarus</b>	<b>Russia</b>	<b>Ukraine</b>
	A2475 washing machine	Car washing machine should be placed on horizontal rails	Car washing machine
Maximum and minimum working heights for train washing equipment		1 000 – 4 000 mm for single deck 610 – 4 500 mm for double deck	0.9 m – 4.4 m
Maximum and minimum speeds for trains passing through washing equipment		5.0 – 5.7 km/h	3.0 – 5.0 km/h;

Maximum length of train (requirement for track length for washing trains)		22 cars	21 cars (1.1 km)
Distance from washing machines (jets, etc) to protruding parts of rolling stock	50 cm	200 mm	0.3 m
Detergent requirements (prohibited ingredients, etc.)		According to applicable public health requirements	According to applicable public health requirements

Lithuania: Equipment is not standardised. Detergents must meet health and environmental requirements.

Poland and Slovakia: no such equipment on 1 520 mm gauge lines.

Conformity assessment method: technical inspection, comparison of geometric dimensions and technical characteristics.

These requirements are approved in the following documents:

Belarus	Operating Instructions on car washing installations Design regulations
Latvia	No regulations. Requirements set in design assignment
Lithuania	No regulations. Requirements set in design assignment
Poland	No regulations.
Russia	[6.11.] Car-Washing Facility for Passenger Trains. Design Specifications. 2006
Slovakia	No regulations.
Ukraine	Design regulations
Estonia	Requirements not standardised. Indirectly referred to in [9.5.] Estonian Railways PTE, sections 8, 9, 48, 49. [9.11.] PPPV 1996 [9.12.] Instructions on Preparation of Freight Cars for Carriage [9.13.] V-010 1998 EVR

Conclusion: The requirements for this parameter are different in different countries and are not standardised in all states. This parameter will require additional study for development of a uniform specification for 1 520 mm gauge system.

### 5.10.3 Water restocking

The requirements for this parameter are different in different countries and are not regulated in all states. In certain cases, an individual approach is applied by agreement between the infrastructure manager and the railway undertaking.

Belarus, Russia, and Ukraine: the main applicable requirements are given in the following table.

	<b>Belarus</b>	<b>Russia</b>	<b>Ukraine</b>
Water quality requirements	Specially prepared water with anticorrosive additives is used for cooling locomotives. A concentrate is used to prepare the water. The water is prepared in tanks.	[1.16.] GOST 2874-82 'Potable Water. Hygienic Requirements and Quality Control'	GOST 2874-82 'Potable Water. Hygienic Requirements and Quality Control'; GOST 2761-84 'Sources of Centralised Household Drinking Water Supply. Hygienic and Technical Requirements, and Sampling Rules'
Coupling		1B according to [1.14] GOST 2593-82 'Coupling Hose Pipes for Railway Rolling Stock Brakes. Specifications'	Brake hose coupling 369-040 (Ø25 mm)
Maximum and minimum pressure in filling system		0.15 to 0.5 MPa	4.0–6.0 kg/cm <sup>2</sup> ; (0.39-0.59 MPa)
System capacity		220 l/min	220 l/min

Latvia and Lithuania: Equipment is not standardised. Water quality standards apply in accordance with national sanitary rules.

Poland and Slovakia: no such equipment on 1 520 mm gauge lines.

Conformity assessment method: technical inspection, comparison of geometric dimensions and technical characteristics.

These requirements are approved in the following documents:

Belarus	[2.10.] TsTChS-50 Instructions on Preparation and Use of Water to Cool Diesel Locomotives and Diesel Multiple-Unit Train Locomotives
Latvia	TsSZhT Rules of 07.03.2001 'Sanitary Rules for Passenger Railway Transport in International Traffic' No regulations on water for passenger use. Set by design technical assignment [3.7.] DR-67/2004 'Instructions on Diesel Engine Cooling Fluid'
Lithuania	TsSZhT Rules of 07.03.2001 'Sanitary Rules for Passenger Railway Transport in International Traffic' [4.17.] HN:2003, 'Potable Water Safety and Quality Requirements'
Poland	Not standardised
Russia	[1.14.] GOST 2593-82 'Coupling Hose Pipes for Railway Rolling Stock Brakes. Specifications'
Slovakia	No regulations.
Ukraine	[1.16.] GOST 2874-82 'Potable Water. Hygienic Requirements and Quality Control' [1.18.] GOST 2761-84 'Sources of Centralised Household Drinking Water Supply. Hygienic and Technical Requirements, and Sampling Rules' [1.14.] GOST 2593-82 'Coupling Hose Pipes for Railway Rolling Stock Brakes. Specifications'
Estonia	Requirements not standardised. Indirectly referred to in [9.5.] Estonian Railways PTE, paragraph 49 [9.11.] PPPV 1996

Conclusion: The requirements for this parameter are different in different countries and are not standardised in all states. This parameter will require additional study for development of a uniform specification for 1 520 mm gauge system.

#### 5.10.4 Sand restocking

The requirements for this parameter are different in different countries and are not standardised in all states. In certain cases, an individual approach applies by agreement between the infrastructure manager and the railway undertaking.

Sand restocking facilities are installed in engine depots and fitting points.

Belarus:

- Humidity not more than 0.5%
- Sand quality. Standard – not less than 75% quartz or more than 3% clay; high quality – not less than 90% quartz or more than 1% clay.

Latvia: Main requirements for quality apply to granular content and composition of quartz:

- Quartz content not less than 75%
- Grain (granular) composition from 0.1 – 2.0 mm

Lithuania: Sand composition requirements (granular composition, quartz content...):

- grain 0.1 - 2 mm;
- working mass of standard quality sand – 90%;
- working mass of high-quality sand – 95%;
- dust content, not more than:
  - standard quality sand passed through a 0.1 mm sieve, residue – 7.0%, clay content – 3.0%;
  - high quality sand passed through a 0.1 mm sieve, residue – 4.0%, clay content – 1.0%
- quartz content:
  - – standard quality sand – 75%
  - – high quality sand – 90%,

Sand humidity requirements: up to 0.5%

Coupling type, maximum and minimum pressure in sand delivery system, and sand delivery capacity are not regulated and are determined in accordance with rolling stock construction requirements.

Ukraine:

- Sand composition requirements (granular composition):
  - Standard quality with quartz content not less than 75% and clay content not more than 3.0%;
  - High quality with quartz content not less than 90% and clay content not more than 1.0%.
- Particle content by size (fraction) – grains in standard and high quality sand must comply with the following table. Data presented as percentage residue after sieving (by mass) through a series of sieves.

Sand quality	Standard size of sieve holes, mm					Dust particles, not more than	
	2.0	1.0	0.5	0.2	0.1	Clay content	Residue in basin*
Normal	None	Not more than 10	Not more than 30	Not less than 30	Not more than 25	3.0	7.0
High	None	Not more than 10	Not more than 30	Not less than 35	Not more than 25	1.0	4.0

\*After passing through 0.1 mm sieve

Sand shipped from quarries for locomotive use shall not contain large fractions; content of grains larger than 2 mm over 2% is permitted only by agreement of the parties.

- The mineral content of standard and high quality sand for locomotive use shall meet the requirements in the following table.

Sand quality	Grain content in washed sand, %	
	Quartz, not less than	Feldspar, and other minerals and rock, not more than
Normal	75	25
High	90	10

- Normal and high quality sand chemical composition must meet the following requirements.

Sand quality	Calcination losses, not more than, %	Silicon dioxide SiO <sub>2</sub> not less than, %	Aluminium oxide (alumina) Al <sub>2</sub> O <sub>3</sub> not more than, %	Other said components: Ca; Mg; (K <sub>2</sub> O+Na <sub>2</sub> O) and others, not more than, %
Normal	1	85	5	9
High	1	92	3	4

- Humidity of sand loaded into locomotive sand boxes must not exceed 0.5%.
- Coupling type: 40 mm metal tube sleeve with cone cap.
- Minimum sand delivery pressure 0.3 MPa (3.0 kgs/cm<sup>2</sup>), maximum – 0.6 MPa (6 kgs/cm<sup>2</sup>).
- Capacity of sand delivery devices: 10 m<sup>3</sup> per day, or 0.42 m<sup>3</sup> per hour.

Conformity assessment method: technical inspection, comparison of geometric dimensions and technical characteristics.

These requirements are approved in the following documents:

Belarus	[1.33.] TsTD-5 Sand for Locomotive Sanding Gear
Latvia	No regulations on installations. Set by design technical assignment [3.8.] DR-72/2005 'Instructions on Sand Quality'
Lithuania	[1.33.] TsTD-5 Sand for Locomotive Sanding Gear
Poland	Set by applicable rules UIC checklists
Russia	Set by design technical assignment. No regulations.
Slovakia	Set by design technical assignment. No regulations.
Ukraine	[8.15.] TU No TsT-0034 'Sand for Locomotive Sanding Gear. Specifications'
Estonia	Requirements not standardised. Indirectly referred to in [9.5.] Estonian Railways PTE, sections 8, 9, 48, 49.

Conclusion: The requirements for this parameter are different in different countries and are not regulated in all states. This parameter will require additional study for development of a uniform specification for 1 520 mm gauge system.

### 5.10.5 Refuelling

The requirements for this parameter are different in different countries and are not regulated in all states. In certain cases, an individual approach applies by agreement between the infrastructure manager and the railway undertaking.

Fuelling stations in locomotive depots, in emergencies – mobile fuelling stations.

Belarus: fuel pumps of various types fitted with liquid volume meters are used to refuel diesel locomotives. RP-40 refuelling guns are used for diesel refuelling.

Latvia: Refuelling equipment is not standardised in railway regulatory documents. Sulphur content of diesel fuel is permitted to 0.05% (50 mg/kg) until 01/01/2009, after 01/01/2009: 0.04% (40 mg/kg). Diesel fuel quality is determined in accordance with the requirements of [3.10.] LVS EN 590 'Diesel Fuel'.

Lithuania: Diesel fuel quality is determined in accordance with the requirements of [4.13.] LST EN 590:2004, Diesel Fuel.

The coupling type (refuelling gun), maximum and minimum refuelling system pressure (automatic cut off when tank is full), and refuelling system capacity is not regulated and is set by the construction requirements of the rolling stock.

Russia: Coal for car heating and diesel for restaurant car cookers are supplied using special road vehicles. Stations must have access routes for such vehicles.

Ukraine: depending on conditions of use, the following marks of diesel fuel are used:

- Л[L] — summer, recommended for use in air temperatures no lower than minus 5 °C.
- З[Z] — winter, recommended for use in air temperatures no lower than minus 15 °C.

Diesel fuel is divided into four types according to sulphur content:

- I - sulphur content by weight not more than 0.05 %
- II - sulphur content by weight not more than 0.10%
- III - sulphur content by weight not more than 0.20 %
- IV - sulphur content by weight not more than 0.50 %

The designation of L grade diesel should include the sulphur content by weight and the flash point; the designation of Z grade diesel should include the sulphur content by weight and freezing point.



Diesel must meet the requirements and standards in table 1 of DSTU 3868-99.

Coupling type (fuel gun) - RP-40.

Maximum pressure in fuelling system – 0.64 MPa (6.4 kgs/cm<sup>2</sup>), minimum – 0.06 MPa (0.6 kgs/cm<sup>2</sup>). No automatic cut out when tank is full.

Fuelling system capacity:

The fuelling system capacity is 4 fuel pumps at 18 m<sup>3</sup>/hour.

Conformity assessment method: technical inspection, comparison of geometric dimensions and technical characteristics.

These requirements are approved in the following documents:

Belarus	[2.11.] TsT-940 Instructions on Use of Lubricants on Locomotives [1.19.] GOST 305 – Diesel Fuel
Latvia	No regulations for installation. Set by design technical assignment [3.9.] DR-77/2007 'Instructions on Lubrication' [3.10.] LVS EN 590 'Diesel Fuel'
Lithuania	[4.13.] LST EN 590:2004, Diesel Fuel.
Poland	[5.15.] EN 590:2004, 'Automatic Refuelling. Diesel. Requirements and Test Methods'
Russia	[6.12] Standard Technological Process for Preparing and Servicing Passenger Trains en Route. 1880.01202.00029 (TK-140) [1.47] Directive 2001/16/EC (Interoperability of Conventional Railways)
Slovakia	Set by design technical assignment. No regulations.
Ukraine	[8.5.] 'DSTU 3868-99. Diesel Fuel. Specifications'
Estonia	Requirements not standardised. Indirectly referred to in [9.5.] Estonian Railways PTE, sections 8, 9, 48, 49. [9.11.] PPPV 1996

Conclusion: The requirements for this parameter are different in different countries and are not standardised in all states. This parameter will require additional study for development of a uniform specification for 1 520 mm gauge system.

### 5.10.6 Electric shore supply

The requirements for this parameter are different in different countries and are not standardised in all states. In certain cases, an individual approach may be applied by agreement between the infrastructure manager and the railway undertaking, including:

- Electrical outlets on sidings,
- Mobile charging stations.
- Outlets and fixed electrical sockets (marshalling yards, sections, passenger train service yards):
  - Direct current (3 kV)
  - Single phase alternating current (3 kV 50 Hz)
  - Socket type:
  - Electrical protection:
- For freight trains (refrigerators)
- For locomotives

Belarus:

- Current from 3 000 V
- Passenger coach outlet.
- T1252 high voltage outlets
- 12 kW chargers
- Requirements for electrical protection

Lithuania:

Current separation protection ( $I_{DN} \leq 30 \text{ mA}$ ) is required for group lines fitted with multiple outlets outside, or in hazardous or highly hazardous premises.

The requirements for voltage, frequency and power, couplings, differences in requirements for electrical supply to different kinds of rolling stock (locomotives, passenger coaches, freight cars, refrigerator cars) are not regulated and are determined by the construction requirements of the rolling stock.

Russia:

Train parking areas must be fitted with devices for connecting shore power supplies in accordance with the requirements of the Federal Passenger Directorate.

Ukraine:

- Charging stations;
- Requirements for voltage, frequency and power – 380V, 50Hz, 5-7kW; 3,000V, 50Hz, 5,600 kVA;
- Coupling ShSh-4x60; RND-35/1000;
- Requirements for electrical protection – VOV25 (high voltage switch);
- Differences in requirements for electrical supply installations for different rolling stock: locomotives, passenger coaches, freight cars – according to PUE (electrical installation operating procedures).
- If diesel is forbidden – electrical generators of refrigerator sections must be capable of connection to a shore supply: 50 Hz frequency, 380-400 V voltage, 150 kW power. Electrical protection – automatic cut out.

Conformity assessment method: technical inspection, comparison of geometrical dimensions and technical characteristics.

These requirements are approved in the following documents:

Belarus	
Latvia	No regulations for installations. Set by design technical assignment
Lithuania	[4.15.] D1-232 'Rules on Installation of Electrical Equipment for Specialised Premises and Technological Processes'
Poland	[1.36.] UIC Leaflet 552 and OSJD Leaflet O+R 556 'Train Electricity Supply, Including Electric Heating' [1.37.] UIC Leaflet O+R 554-1 'Power Supply to Electrical Equipment on Stationary Railway Vehicles (220 V, 380 V, 50 Hz)'

Russia	[1.36.] UIC Leaflet 552 and OSJD Leaflet O+R 556 'Train Electricity Supply, Including Electric Heating' [1.37.] UIC Leaflet O+R 554-1 'Power Supply to Electrical Equipment on Stationary Railway Vehicles (220 V, 380 V, 50 Hz)'
Slovakia	Set by design technical assignment. No regulations.
Ukraine	[8.16.] Rules on Operation of Electrical Devices
Estonia	Requirements not standardised. Indirectly referred to in [9.5.] Estonian Railways PTE, sections 8, 9, 48, 49. [9.11.] PPPV 1996 [9.12.] Instructions on Preparation of Freight Cars for Carriage [9.13.] V-010 1998 EVR

Conclusion: The requirements for this parameter are different in different countries and are not regulated in all states. This parameter will require additional study for development of a uniform specification for 1 520 mm gauge system.

## **6 COMPARISON WITH TARGET VALUES OF 1435 MM GAUGE SYSTEMS**

The main obstacle to 1 435 mm gauge trains running on 1 520 mm lines, and vice-versa, is the difference in gauge. However, it is not the sole obstacle. This section compares each of the 1 520 mm gauge parameters above with the target values of the 'basic parameters' of the 1 435 mm gauge system. The purpose of the comparison is to identify the various obstacles preventing 1 435 mm gauge trains from operating on 1 520 mm gauge lines, and 1 520 mm gauge trains from operating on 1 435 mm gauge lines.

The target values of the main parameters of the 1 435 mm gauge system are to be established by the Infrastructure TSI, the 'Locomotives, Traction Units, and Passenger Coaches' TSI, and other TSI, which are currently being drafted pursuant to the Directive on Interoperability of the Trans-European Conventional Rail System.

The draft TSI set maximum values for certain parameters based on line category. Both the line categorisation and the underlying principle differ from the categorisation applied in 1 520 mm systems. Therefore, a generalised comparison is not always possible.

### **6.1 TRACK PARAMETERS**

#### **6.1.1 Minimum structure gauge**

The draft [1.51.] Infrastructure TSI refers to sections 5, 7, 10 and Annex C of the draft prEN 15273-3:2008 and sets the minimum structure gauge as GC, GB or GA depending on line category.

#### **6.1.2 Distance between track centres**

The draft [1.51.] Infrastructure TSI refers to the minimum structure gauge for GC, GB and GA depending on line category.

Rules for taking aerodynamic effects into consideration are to be introduced into this document in the future.

#### **6.1.3 Maximum gradients**

The draft [1.51.] Infrastructure TSI provides different values depending on the purpose of the line (passenger, freight, mixed use). The requirements for track at passenger platforms

and sidings are particularly emphasised. The maximum permitted gradient is 12.5-35 mm/m, depending on line category and length of section.

Differences in line categorisation do not permit a general comparison.

#### **6.1.4 Minimum radius of horizontal curve**

The draft [1.51.] Infrastructure TSI sets the absolute minimum at 150 m. For S-bends, the draft refers to section 8.4 of the EN 13803-2:2006 standard.

The specifications for this parameter in 1 520 mm gauge system allow 1 435 mm gauge trains to operate on 1 520 gauge lines.

#### **6.1.5 Minimum radius of vertical curve**

The draft [1.51.] Infrastructure TSI sets an absolute minimum only for sidings, service track and marshalling yard humps.

The value of this parameter for marshalling yard humps does not match the values for 1 520 mm gauge system:

	1 520 mm gauge	1 435 mm gauge Draft Infrastructure TSI
Incline section of hump	At least 350 m	At least 250 m
Decline section of hump	At least 250 m	At least 300 m

#### **6.1.6 Length of station entry and departure tracks**

The longest train length provided for in the draft [1.51.] Infrastructure TSI is 750 m. Therefore, the length of 1 520 mm gauge railways station entry and departure tracks is not an obstacle for 1 435 mm gauge trains.

## 6.2 TRACK PARAMETERS

### 6.2.1 Gauge

One of the following methods must be used to overcome the barrier created by the difference in gauge:

- Variable gauge rolling stock
- Replacement of bogies or wheelsets

On certain sections, it is possible to build four-rail tracks:

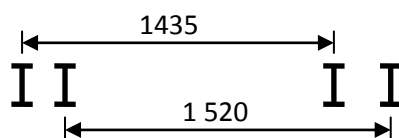

### 6.2.2 Cant

The draft [1.51.] Infrastructure TSI sets maximum cant at 180 mm and 160 mm, depending on line category. Cant at platforms must not exceed 110 mm.

The specifications of this parameter for 1520 mm gauge system enable 1435 mm gauge trains to run. Additional checks are required for curves with a radius of less than 275 m and track at platforms.

### 6.2.3 Cant deficiency

The draft [1.51.] Infrastructure TSI sets the maximum at 130 mm for freight cars and 150 mm for locomotives, traction units and passenger coaches.

The specifications of this parameter for 1520 mm gauge system enable 1435 mm gauge trains to run.

#### 6.2.4 Rate of change of cant

The draft [1.51.] Infrastructure TSI provides for a rate of change of cant of up to 70 mm/s for the maximum permitted train speed. The following table compares this requirement with the Russian requirements:

[6.4.] Instructions on the Routine Maintenance of Railway Tracks, TsP-774 Section 2.1.6. (Russia)			Requirements in draft [1.51.] Infrastructure TSI(for 70 mm/s)
Rate of change of cant, mm/m		Train speed, km/h	
Recommended	Permitted maximum		
0.5	0.7	140	1.80
0.8	1.0	120	2.10
0.9	1.2	110	2.29
1.0	1.4	100	2.52
1.2	1.6	90	2.80
1.4	1.7	85	2.96
1.6	1.9	80	3.15
1.8	2.1	75	3.36
1.9	2.3	70	3.60
2.0	2.5	65	3.88
2.1	2.7	60	4.20
2.3	2.9	55	4.58
2.5	3.0	50	5.04
2.7	3.1	40	6.30
3.0	3.2	25	10.08
	More than 3.2	Line closes	

Therefore, the rate of change of cant in the 1 520 mm gauge system is not an obstacle to 1 435 mm gauge trains operating.



### **6.2.5 Railhead profile for plain track**

The draft [1.51.] Infrastructure TSI sets requirements for cross-section of railhead only.

Of the rails used in the 1 520 mm gauge system, R65 and R50 rails do not conform to the requirements in the draft Infrastructure TSI. These rails have a vertical distance between the top of the side face and the crown of the rail of 15.7 mm and 15.4 mm, respectively, which exceeds the maximum value in the draft [1.51.] Infrastructure TSI (15.0 mm).

### **6.2.6 Equivalent conicity**

The draft [1.51.] Infrastructure TSI establishes this parameter for train speeds  $\geq 60$  km/h. The Latvian, Lithuanian and Estonian railways have a maximum speed of 120 km/h, which is to rise to 160 km/h.

As stated in section 5.2.6, the parameter of equivalent conicity in the 1 520 mm gauge system is not defined or standardised.

### **6.2.7 Rail inclination**

The values in the draft [1.51.] Infrastructure TSI (1/20 and 1/40) are within the permitted limits for 1 520 mm (from 1/12 to 1/60).

### **6.2.8 Track stiffness**

In the draft [1.51.] Infrastructure TSI, this parameter is an 'open issue' and no comparison is possible.

In the [1.51.] Infrastructure TSI, the following definition is provided for high-speed railways: 'Global track stiffness: A measure of the displacement of the rail under wheel loading'.

### **6.2.9 Electric Insulation of Rails**

In the draft [1.51.] Infrastructure TSI, the minimum specific resistance is 3 Ohm·km. This parameter is linked to compatibility with the signalling system.

Therefore, the electrical insulation of 1 520 mm gauge lines is not an obstacle to 1 435 mm gauge trains running.

## 6.3 SWITCHES AND CROSSINGS

### 6.3.1 Means of locking

The only requirement for this parameter in the [1.51.] Infrastructure TSI is that there is a means of locking.

Therefore, this parameter is not an obstacle to running 1 435 mm gauge trains.

### 6.3.2 In service geometry of switches and crossings

The draft [1.51.] Infrastructure TSI sets the following series of 'subparameters'.

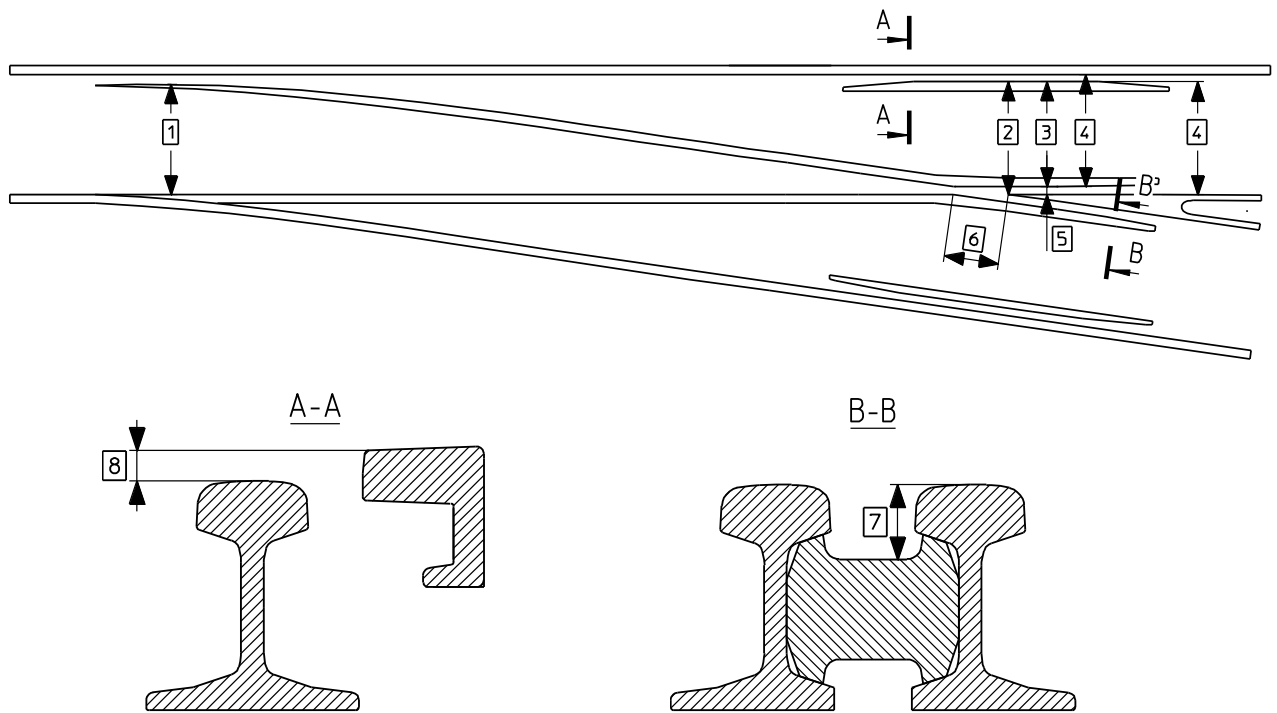

Variable according to draft [1.51.] Infrastructure TSI	Corresponding variables used in the 1 520 mm gauge system
1. Distance between gauge face of one switch blades and outer face of the opposite blade.	In theory, this parameter and the 'Opening between the second (non-gauge) blade and the check rail' used in the 1 520 mm gauge system refer to the same thing - the ability of the wheel flange to pass through the switch when the blade is open.

<b>Variable according to draft [1.51.] Infrastructure TSI</b>	<b>Corresponding variables used in the 1 520 mm gauge system</b>
2. Distance between nose of frog and gauge face of opposite check rail.	This parameter corresponds to the 'Distance from gauge face of frog and gauge face of guard rail crown' parameter used in the 1 520 mm gauge system.
3. Distance between gauge face of guard rail and gauge face of opposite guard rail.	This parameter corresponds to the 'Distance between gauge face of guard rail and check rail crowns' parameter used in the 1 520 mm gauge system.
4. Distance between gauge face of guard rail or check rail and gauge face of opposite rail, measured, respectively, at start of guard or check rail.	In theory, this and 'width of flangeway at guard rail opening at entry' and 'width of flangeway at check rail opening at entry' used in the 1 520 mm gauge system refer to the same thing – the ability of the wheel flange to pass unobstructed through the gap between rail and guard rail.
5. Distance between gauge face of guard rail or check rail and gauge face of adjacent rail.	In theory, this and the 'width of flangeway in straight section of guard rail' and 'width of flangeway at point and to frog centre' used in the 1 520 mm gauge system refer to the same thing – the ability of the wheel flange to pass unobstructed through the gap between the rail and guard rail.
6. Maximum unguided length (section of switch or crossing in which the wheel flange is not guided by the gauge face) (separate parameter)	See section 6.3.3.
7. Distance between running surface and flangeway in gap for wheel flange,	See switch construction: in the switch blade - 50 mm, in the frog - 56 to 60 mm.

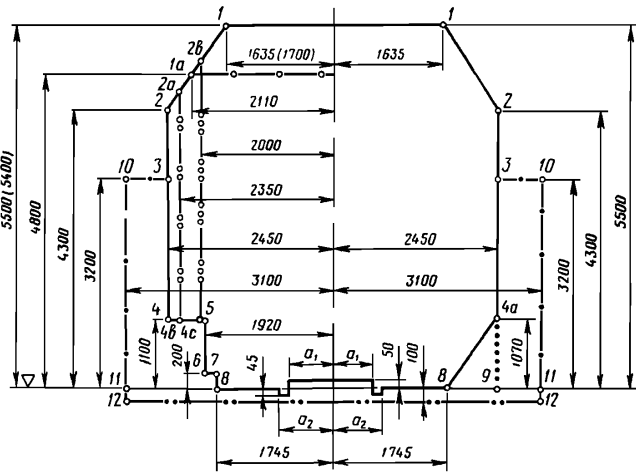
Variable according to draft [1.51.] Infrastructure TSI	Corresponding variables used in the 1 520 mm gauge system
8. Height of guard rail over adjoining rail.	<p>Not monitored in operation. This variable falls within the scope of [1.12.] GOST 9238-83 '1 520 (1 524) mm Gauge Railway Minimum Gauges for Structures and Rolling Stock' (in Latvia - [3.2.] LVS 282-2005 'Structure and Loading Gauges').</p> <p>Dimension Sr:</p>  <p>Therefore, this variable should not exceed 50 mm; for Russia – 20 mm.</p>

### 6.3.3 Maximum unguided length of fixed obtuse crossings

The draft [1.51.] Infrastructure TSI sets the maximum unguided length as equal to the result of the angle of deviation of a number 1:9 blunt nose frog switch with guide devices 45 mm above the running surface for a minimum diameter of 330 mm on straight sections.

For 1 520 mm gauge lines in Poland, [1.51.] Infrastructure TSI specifically allows guide devices 44 mm above the running surface.

## 6.4 TRACK RESISTANCE TO APPLIED LOADS

### 6.4.1 Track resistance to vertical loads

The draft [1.51.] Infrastructure TSI sets axle loads at 20.0 t, 22.5 t and 25.0 t, depending on line category. The maximum for passenger trains is – 22.5 t.

The specifications for this parameter in the 1 520 mm gauge system allow for 1 435 mm passenger trains to run. Additional examination will be required for freight trains in each particular case.

#### **6.4.2 Longitudinal track resistance**

According to the draft [1.51.] Infrastructure TSI, track construction shall withstand maximum permitted braking speeds (2.5 m/s<sup>2</sup>).

The draft Infrastructure TSI allows the Infrastructure Manager to impose prohibitions or restrictions on the use of braking systems that convert kinetic energy of the rolling stock into heat in rails (electromagnetic breaks, eddy current brakes).

Where such systems are permitted, the maximum permitted emergency braking force for the entire train shall not exceed 360 kN.

#### **6.4.3 Lateral track resistance**

The draft [1.51.] Infrastructure TSI sets maximum values for

- Dynamic lateral force exerted by the wheelset on the track:  $(\Sigma Y_{2m})_{lim} = 10 + (P/3)$  kN (where 'P' – is axle load in kN) and
- Quasi-static guiding force exerted by a wheelset on the track:  $(Y_{qst})_{lim} = (30 + 10500/R_m)$  kN (for curves  $250 \leq R_m < 400$ , where 'R<sub>m</sub>' – is the curve radius in m).

### **6.5 STRUCTURES RESISTANCE TO TRAFFIC LOADS**

#### **6.5.1 Resistance of bridges to traffic loads**

The 1 520 mm gauge system generally assumes large axle loads, however the calculation models applied differ. For a more detailed analysis, these models need to be compared.

### **6.5.2 Equivalent vertical loading for earthworks and earth pressure effects**

The 1 520 mm gauge system generally assumes large axle loads, however the calculation models applied differ. For a more detailed analysis, these models need to be compared.

### **6.5.3 Resistance of structures over or adjacent to tracks**

The draft [1.51.] Infrastructure TSI refers to section 6.6 of [1.25.] EN 1991-2:2003. Eurocode 1: Action on Structures – Part 2. Traffic Loads on Bridges.

As indicated in section 5.5.3, the load on structures over or adjacent to tracks in the 1 520 mm gauge system is not defined or standardised at present.

## **6.6 TRACK GEOMETRICAL QUALITY AND DEFECTS LIMITS ON ISOLATED SECTIONS**

### **6.6.1 Determination of immediate action, intervention, and alert limits**

The approach to this parameter in documents for the 1 520 mm gauge system is similar to the approach in the draft [1.51.] Infrastructure TSI, but the precise definitions of the monitored variables of geometric quality differ.

### **6.6.2 Immediate action limit for track twist**

See section 6.6.1.

### **6.6.3 Immediate action limit for variation of track gauge**

See section 6.6.1.

### **6.6.4 Immediate action limit for cant**

See section 6.6.1.

## **6.7 PLATFORMS**

### **6.7.1 Usable length of platforms**

The draft [1.51.] Infrastructure TSI does not set specific values for platform length. The [1.52.] Locomotives, Traction Units, and Passenger coaches TSI sets a maximum passenger train length of 400 m.

The specifications for this parameter in the 1 520 mm gauge system, in most cases, allow 1 435 mm gauge passenger trains to operate. Additional study is required depending on each particular case.

### **6.7.2 Width and edge of platforms**

The specifications for this parameter concern the safety of persons on the platform while trains are passing. The speed limit set by the infrastructure manager shall in each case conform to the platform characteristics.

Subject to compliance with this requirement, this parameter for 1 520 mm gauge system is not an obstacle for 1 435 mm trains operating.

### **6.7.3 Height of platforms (high and low)**

The [1.51] Persons with Reduced Mobility TSI establishes the heights for new platforms: 550 mm, 760 mm (- 35 mm + 0 mm) from the level of the railhead.

For Latvia, Lithuania and Estonia, platform heights of 200 mm and 1 100 mm (+20 mm -50 mm) from the level of the railhead are also permitted, which corresponds to the requirements in the 1 520 mm gauge space.

### **6.7.4 Offset of platforms**

The Persons with Reduced Mobility TSI sets the platform offset (straight track, no switches): 1 650 mm.

This distance does not match gauge 'S' in the 1 520 mm gauge system. Therefore, for Latvia, Lithuania and Estonia, the document has special provisions: 1 920 mm for platform heights of 1 100 mm and 1 745 mm for platform heights of 200 mm, which matches the requirements in the 1 520 mm gauge space.

### **6.7.5 Characteristics of platforms linked to the access of people with reduced mobility**

The specifications for this parameter are not related to interoperability of infrastructure and rolling stock.

The specifications for this parameter in the 1 520 mm gauge system do not obstruct the operation of 1 435 mm trains.

### **6.7.6 End of platforms**

The specifications for this parameter are not related to interoperability of infrastructure and rolling stock.

The specifications for this parameter in the 1 520 mm gauge system do not obstruct the operation of 1 435 mm.

## **6.8 HEALTH, SAFETY AND ENVIRONMENT**

### **6.8.1 Maximum pressure variation in tunnels**

According to the draft [1.51.] Infrastructure TSI, this parameter applies at speeds  $\geq$  190 km/h. In Latvia, Lithuania and Estonia, the maximum speed is 120 km/h, which is to rise to 160 km/h in the future.

As stated in section 5.8.1, changes in tunnel pressure in the 1 520 mm gauge system are not standardised at present.

The absence of specifications for this parameter in the 1 520 mm gauge system is not an obstacle to operation of 1 435 mm trains at speeds under 190 km/h.

### **6.8.2 Piston effects in underground stations**

As piston effects depend on the layout of each particular station, the draft [1.51.] Infrastructure TSI requires special study in each particular case. These requirements may be fully applied in the 1 520 mm gauge system.

As stated in section 5.8.2, piston effects in underground stations are not standardised in the 1 520 mm gauge system at present.



Given the difference in size of rolling stock in the 1 520 mm and 1 435 mm gauge systems, the piston effect of a 1 435 mm gauge train will be less than that of a 1 520 mm gauge train.

The absence of specifications for this parameter in the 1 520 mm gauge system is not an obstacle to operation of 1 435 mm trains.

### **6.8.3 Noise and vibration limits and mitigation measures**

According to the draft [1.51.] Infrastructure TSI, this parameter is an 'open issue', so comparison is not possible.

In the [1.51.] Infrastructure TSI, the requirements for rolling stock are presented.

### **6.8.4 Protection against electric shock**

The draft Infrastructure TSI refers to the TSI Energy, which sets requirements for

1. Earthing,
2. Protection by separation,
3. Fencing,
4. Electrical insulation,
5. Monitoring the potential difference between the rails and ground.

Means of protection must comply with EN50119:2001 and EN50122-1:1997.

### **6.8.5 Safety in railway tunnels**

In the [1.56.] Safety in Rail Tunnels TSI, requirements are set for the subsystem infrastructure for the following parameters:

- Placement of switches and crossings in tunnels,
- Prevention of unauthorised access,
- Structural fire safety requirements,
- Fire safety requirements for construction materials,

- Fire detection systems,
- Equipment for emergency exit, evacuation and rescue in the event of an incident,
- Emergency exit routes,
- Emergency lighting for emergency exit routes,
- Emergency exit routes,
- Emergency communications devices,
- Rescue service access,
- Rescue facilities near tunnels,
- Water supplies

#### **6.8.6 Effect of crosswinds**

In the draft [1.51.] Infrastructure TSI, this parameter is an 'open issue', so comparison is not possible.

### **6.9 PROVISION FOR OPERATION**

#### **6.9.1 Distance markers**

In regard to this parameter, the sole requirement in the draft [1.51.] Infrastructure TSI is the presence of distance markers with the nominal distance between markers stated in the Register of Infrastructure. These requirements may be fully applied in 1 520 mm gauge system.

Therefore, this parameter is not an obstacle to operation of 1 435 mm gauge trains.

### **6.10 FIXED INSTALLATIONS FOR SERVICING TRAINS**

#### **6.10.1 Toilet discharge**

In regard to this parameter, the [1.51.] Infrastructure TSI states that the installations should comply with Annex M VI of the HS Rolling Stock TSI, which provides a diagram.

The installations should be compared according to the [1.35.] 'OSJD Leaflet O+R 563 'Solutions and Recommendations for the Standardisation of Sanitation Facilities in Passenger coaches', 2nd edition" and its requirements.

### **6.10.2 Train external cleaning facilities**

The draft [1.51.] Infrastructure TSI contains the following requirement: the washing plant shall be designed so that the train can be driven through at 5 km/h. This requirement matches the system of automatic control of train speeds over 5 km/h.

These requirements are contrary to the requirements in effect in certain countries for 1 520 mm gauge system.

There are also differences in the range of operating heights (height from-to) for washing plants in the 1 520 mm gauge and 1 435 mm gauge systems.

### **6.10.3 Water restocking**

In regard to this parameter, the draft [1.51.] Infrastructure TSI requires drinking water quality to comply with [1.50.] Directive 98/83/EC.

Couplings must comply with Annex M V [1.53.] Rolling Stock for High Speed Rail TSI, which provides a diagram.

The Type 1B coupling in [1.14.] GOST 2593-82 'Coupling Hose Pipes for Railway Rolling Stock Brakes. Specifications' should be compared with these requirements.

### **6.10.4 Sand restocking**

In regard to this parameter, the draft [1.51.] Infrastructure TSI cites the [1.53.] Rolling Stock for High Speed Rail TSI, in which the sole requirement is that sand meet local specifications.

Therefore, this parameter does not present an obstacle to operation of 1 435 mm trains.

### **6.10.5 Refuelling**

For this parameter, the draft [1.51.] Infrastructure TSI states that refuelling equipment must comply with [1.47.] UIC Leaflet 627-2 'Refuelling Equipment for Diesel Rolling Stock' section 1 (the EN standard is in development).

Refuelling equipment for other fuels is an 'open issue'.

#### **6.10.6 Electrical shore supply**

For this parameter, the draft [1.51.] Infrastructure TSI cites the [1.53.] Rolling Stock for High Speed Rail TSI, which provides for:

- Supply from the contact system
- Electrical supply according to [1.36.] UIC Leaflet 552 and OSJD Leaflet O+R 556 'Train Electricity Supply, Including Electric Heating' (1 kV alternating current, 1.5 kV alternating or direct current, 3 kV direct current)
- Local supply: 'open issue', proposed draft MODPOWER: 3x400 V, 63 A, 50 Hz

[1.36.] UIC Leaflet 552 and OSJD Leaflet O+R 556 'Train Electricity Supply, Including Electric Heating' is used in both the 1 520 mm gauge system and the 1 435 mm gauge system.

## **7 ANNEXES**

### **7.1 MEMBERS OF CONTACT GROUP**

### **7.2 MATTERS FOR FURTHER STUDY**

**ANALYSIS OF THE BASIC PARAMETERS FOR  
MAINTAINING THE TECHNICAL AND  
OPERATIONAL COMPATIBILITY OF THE 1 520 mm  
AND 1435 mm GAUGE RAIL SYSTEMS AT THE  
COMMONWEALTH OF INDEPENDENT STATES  
(CIS)-EUROPEAN UNION (EU) BORDER**

**SUBSYSTEM: INFRASTRUCTURE.  
PERMANENT WAY AND FACILITIES TRACK**

**APPENDIX 2**

**A LIST OF QUESTIONS**

**REQUIRING FURTHER INVESTIGATION**

**Document prepared by the OSJD - ERA Contact Group**

**(Translation from the original in Russian)**

**JANUARY 2009**

**REVISIONS AND AMENDMENTS**

<b>Revision and date</b>	<b>Sections</b>	<b>Explanation</b>	<b>Author</b>
0.05/ 10/09/2008	1, 2	Working document based on information received from ERA before 10/09/08.	FAD
0.07/ 10/12/2008	1, 2	Preliminary draft for agreement at next meeting	FAD
1.00/ 27/01/2009	-	Document agreed by the Contact Group	VK
1.01/ 19.03.2009	Title of the document, 1	Addition “and 1435” according to a of decision of the Empowered representatives of members of Conference of Ministers of OSJD and Conference of Director Generals	VK FAD

## CONTENTS

1	INTRODUCTION.....	3
2	LIST OF QUESTIONS REQUIRING ADDITIONAL INVESTIGATION.....	4
2.1	<b>Line layout.....</b>	<b>4</b>
2.2	<b>Track parameters.....</b>	<b>4</b>
2.3	<b>Switches and crossings.....</b>	<b>4</b>
2.4	<b>Track resistance to applied loads.....</b>	<b>5</b>
2.5	<b>Structures resistance to traffic loads.....</b>	<b>5</b>
2.6	<b>Track geometrical quality and limits on isolated defects.....</b>	<b>5</b>
2.7	<b>Platforms.....</b>	<b>5</b>
2.8	<b>Health, safety and environment.....</b>	<b>6</b>
2.9	<b>Provision for operation.....</b>	<b>6</b>
2.10	<b>Fixed installations for servicing trains.....</b>	<b>6</b>



## 1 INTRODUCTION.

The ERA/OSJD Contact Group has prepared this “Analysis of the determining parameters for ensuring the technical and operational compatibility of the 1520 mm gauge rail system at the CIS-EU border, Subsystem: Infrastructure. Track and permanent way” based on information submitted by the OSJD member states represented on the Contact Group. This information has been summarised as far as possible.

The requirements of the normative documents of the various countries are identical or vary only slightly as regards the parameters. Where this does happen, in preparing a unified specification for the 1520 mm gauge system, these minor differences can be resolved within the framework of the Working Group involved in drawing up the document.

At the same time the requirements for several of the parameters examined differ substantially between different countries and several parameters are not regulated either in some of the countries or in terms of the 1520 mm gauge system as a whole. A more in-depth study of these parameters will be needed when drawing up a unified specification for the 1520 mm gauge system.

This Appendix contains a list of the parameters requiring more in-depth investigation.

## **2 LIST OF QUESTIONS REQUIRING ADDITIONAL INVESTIGATION.**

First and foremost it should be pointed out that the specification of some parameters is fixed according to line classification. Both the classification of lines and the approach to their classification vary in different states.

When preparing a unified specification for these parameters for the 1520 mm gauge system the priority requirement is for a unified classification of the railway lines.

The questions requiring additional more-in depth study are given for each group of parameters.

### **2.1 *Line layout***<sup>1</sup>

- *Maximum gradients. (ascent/descent).* At present a summary analysis of this parameter is difficult to make because of the heterogenous nature of the line classifications being used.

### **2.2 *Track parameters***

- *Rate of change of cant.*
- *Equivalent conicity.* At present there is no fixed or standard equivalent conicity parameter for the 1520 mm gauge system.
- *Track stiffness.* At present there is no standard for this parameter as such. In practice the track structure and component requirements (earthworks, ballast shoulder, fastening etc.) are used.

### **2.3 *Switches and crossings***

No questions.

---

<sup>1</sup> English terms used in the original Russian document

#### **2.4 *Track resistance to applied loads***

- *Longitudinal track resistance.* At present there is no standard for this parameter as such, or the approach is heterogenous. In practice the track structure and component requirements (anti-creep devices) are applied.
- *Lateral track resistance.* At present there is no standard for this parameter as such, or the approach is heterogenous. In practice the ballast shoulder requirements are applied (inclination of slope, width of [ballast] shoulder etc., depending on load intensity, sleeper type and radius of curve).

#### **2.5 *Structures resistance to traffic loads***

- *Resistance of bridges to traffic loads.* Detailed comparison of calculation models.
- *Equivalent vertical loading for earthworks and earth pressure effects.* Detailed comparison of calculation models.
- *Resistance of structures over or adjacent to tracks.* At present there is no standard for this parameter as such.

#### **2.6 *Track geometrical quality and limits on isolated defects***

No questions.

#### **2.7 *Platforms***

- *Usable length of platforms.* At present the approach to this parameter in different states is different; not all states have a standard.
- *Width and edge of platforms.* At present the approach to this parameter in different states is different; not all states have a standard.
- *Characteristics of platforms linked to the access of people with reduced mobility.* At present the approach to this parameter in different states is different; not all states have a standard..
- *Width and edge of platforms, End of platforms.* At present the approach to this parameter in different states is different; not all states have a standard.

## **2.8 Health, safety and environment**

- *Maximum pressure variation in tunnels.* At present there are no standards for this parameter.
- *Piston effects in underground stations.* At present there are no standards for this parameter.
- *Noise and vibration limits and mitigation measures.* At present the approach to this parameter in different states is different; not all states have a standard.
- *Safety in railway tunnels.* At present the approach to this parameter in different states is different; not all states have a standard.
- *Effect of crosswinds.* At present there are no standards for this parameter.

## **2.9 Provision for operation**

No questions.

## **2.10 Fixed installations for servicing trains**

- *Toilet discharge.* At present the approach to this parameter in different states is different and not all states have a standard..
- *Train external cleaning facilities.* At present the approach to this parameter in different states is different; and not all states have a standard.
- *Water restocking.* At present the approach to this parameter in different states is different; and not all states have a standard.
- *Sand restocking.* At present the approach to this parameter in different states is different; and not all states have a standard.
- *Refuelling.* At present the approach to this parameter in different states is different; and not all states have a standard.
- *Electric shore supply.* At present the approach to this parameter in different states is different; and not all states have a standard.